

DOCUMENT RESUME

ED 092 162

IR 000 723

AUTHOR Cotton, Ira W.
TITLE Network Management Survey.
INSTITUTION National Bureau of Standards (DOC), Washington, D.C.
SPONS AGENCY National Science Foundation, Washington, D.C.
REPORT NO NBS-TN-805
PUB DATE Feb 74
NOTE 93p.
AVAILABLE FROM Superintendent of Documents, U.S. Government Printing Office, Washington, D.C. 20402 (SD Cat. No. C13.46:805, \$1.20)

EDRS PRICE MF-\$0.75 HC-\$4.20 PLUS POSTAGE
DESCRIPTORS Administrative Organization; Administrative Policy; *Administrative Problems; *Computer Science; Financial Policy; *Information Networks; *Management; *Program Descriptions; Surveys; Telecommunication
IDENTIFIERS ARPA Network; *Computer Networks; MERIT Network; Oregon State Regional Network; Triangle Universities Computation Center; Tymnet

ABSTRACT

A study was made of management practices in different computer networks. The five networks were chosen as typical of different approaches to network implementation and management: Defense Advanced Research Projects Agency (ARPA) Network, MERIT Network, Triangle Universities Computation Center (TUCC), Oregon State Regional Network, and Tymnet (a commercial network). A common format which included questions about network mission, technology and organization; financial and legal concerns; and summary of problems and tentative recommendations was used to survey each organization. The resulting report is not intended to be prescriptive, although some empirical observations are presented for each topic covered. (Author/SL)

A UNITED STATES
DEPARTMENT OF
COMMERCE
PUBLICATION

NBS TECHNICAL NOTE 805

TR



ED 092162

Network Management Survey

U.S.
DEPARTMENT
OF
COMMERCE
National
Bureau
of
Standards



NATIONAL BUREAU OF STANDARDS

The National Bureau of Standards¹ was established by an act of Congress March 3, 1901. The Bureau's overall goal is to strengthen and advance the Nation's science and technology and facilitate their effective application for public benefit. To this end, the Bureau conducts research and provides: (1) a basis for the Nation's physical measurement system, (2) scientific and technological services for industry and government, (3) a technical basis for equity in trade, and (4) technical services to promote public safety. The Bureau consists of the Institute for Basic Standards, the Institute for Materials Research, the Institute for Applied Technology, the Institute for Computer Sciences and Technology, and the Office for Information Programs.

THE INSTITUTE FOR BASIC STANDARDS provides the central basis within the United States of a complete and consistent system of physical measurement; coordinates that system with measurement systems of other nations; and furnishes essential services leading to accurate and uniform physical measurements throughout the Nation's scientific community, industry, and commerce. The Institute consists of a Center for Radiation Research, an Office of Measurement Services and the following divisions:

Applied Mathematics — Electricity — Mechanics — Heat — Optical Physics — Nuclear Sciences² — Applied Radiation³ — Quantum Electronics³ — Electromagnetics³ — Time and Frequency³ — Laboratory Astrophysics³ — Cryogenics³.

THE INSTITUTE FOR MATERIALS RESEARCH conducts materials research leading to improved methods of measurement, standards, and data on the properties of well-characterized materials needed by industry, commerce, educational institutions, and Government; provides advisory and research services to other Government agencies; and develops, produces, and distributes standard reference materials. The Institute consists of the Office of Standard Reference Materials and the following divisions:

Analytical Chemistry — Polymers — Metallurgy — Inorganic Materials — Reactor Radiation — Physical Chemistry.

THE INSTITUTE FOR APPLIED TECHNOLOGY provides technical services to promote the use of available technology and to facilitate technological innovation in industry and Government; cooperates with public and private organizations leading to the development of technological standards (including mandatory safety standards), codes and methods of test; and provides technical advice and services to Government agencies upon request. The Institute consists of a Center for Building Technology and the following divisions and offices:

Engineering and Product Standards — Weights and Measures — Invention and Innovation — Product Evaluation Technology — Electronic Technology — Technical Analysis — Measurement Engineering — Structures, Materials, and Life Safety⁴ — Building Environment⁴ — Technical Evaluation and Application⁴ — Fire Technology.

THE INSTITUTE FOR COMPUTER SCIENCES AND TECHNOLOGY conducts research and provides technical services designed to aid Government agencies in improving cost effectiveness in the conduct of their programs through the selection, acquisition, and effective utilization of automatic data processing equipment; and serves as the principal focus within the executive branch for the development of Federal standards for automatic data processing equipment, techniques, and computer languages. The Institute consists of the following divisions:

Computer Services — Systems and Software — Computer Systems Engineering — Information Technology.

THE OFFICE FOR INFORMATION PROGRAMS promotes optimum dissemination and accessibility of scientific information generated within NBS and other agencies of the Federal Government; promotes the development of the National Standard Reference Data System and a system of information analysis centers dealing with the broader aspects of the National Measurement System; provides appropriate services to ensure that the NBS staff has optimum accessibility to the scientific information of the world. The Office consists of the following organizational units:

Office of Standard Reference Data — Office of Information Activities — Office of Technical Publications — Library — Office of International Relations.

¹ Headquarters and Laboratories at Gaithersburg, Maryland, unless otherwise noted; mailing address Washington, D.C. 20234.

² Part of the Center for Radiation Research.

³ Located at Boulder, Colorado 80302.

⁴ Part of the Center for Building Technology.

Network Management Survey

Ira W. Cotton

Computer Systems Engineering Division
Institute for Computer Sciences and Technology
National Bureau of Standards
Washington, D.C. 20234

Sponsored by the
National Science Foundation
18th and G Street, N.W.
Washington, D.C. 20550



U.S. DEPARTMENT OF HEALTH
EDUCATION & WELFARE
NATIONAL INSTITUTE OF
EDUCATION

THIS DOCUMENT HAS BEEN REPRODUCED EXACTLY AS RECEIVED FROM THE PERSON OR ORGANIZATION ORIGINATING IT. POINTS OF VIEW OR OPINIONS STATED DO NOT NECESSARILY REPRESENT OFFICIAL NATIONAL INSTITUTE OF EDUCATION POSITION OR POLICY.

U.S. DEPARTMENT OF COMMERCE, Frederick B. Dent, *Secretary*
NATIONAL BUREAU OF STANDARDS, Richard W. Roberts, *Director*

Issued February 1974

National Bureau of Standards Technical Note 805

Nat. Bur. Stand. (U.S.), Tech. Note 805, 91 pages (Feb. 1974)

CODEN: NBTNAE

**U.S. GOVERNMENT PRINTING OFFICE
WASHINGTON: 1974**

For sale by the Superintendent of Documents, U.S. Government Printing Office, Washington, D.C. 20402
(Order by SD Catalog No. C13.46:805). Price \$1.20

Foreword

This report is one of a series of publications produced by the Institute for Computer Sciences and Technology, National Bureau of Standards, under Grant AG-350 from the National Science Foundation.

This grant supports a broad program of investigation into the foundations of computer networking in support of scientific and related educational efforts.

A listing of completed and planned publications produced by the Institute under this grant follows:

1. "Primary Issues In User Needs"
D. W. Fife
Chapter 10 In <Networks for Research and Education:
Sharing of Computer and Information Resources
Nationwide>
MIT Press, Cambridge, Massachusetts
Expected Publication: January 1974
2. "Some Technical Considerations for Improved
Service to Computer Users"
T. N. Pyke, Jr.
COMPCON 1973
Seventh Annual IEEE Computer Society
International Conference
3. "Computer Networking Technology - A
State of the Art Review"
T. N. Pyke, Jr. and R. P. Blanc
COMPUTER Magazine
Computer Society of the IEEE
August, 1973
4. "Review of Network Management Problems and Issues"
A. J. Neumann
October, 1973
NBS Technical Note No. 795
5. "Annotated Bibliography of the Literature on
Resource Sharing Computer Networks"
R. P. Blanc, I. W. Cotton, T. N. Pyke, Jr.
and S. W. Watkins
September, 1973
NBS Special Publication 384

6. "Network Management Survey"
I. W. Cotton
February, 1974
NBS Technical Note No. 805
7. "User Procedures Standardization for
Network Access"
A. J. Neumann
October, 1973
NBS Technical Note No. 799
8. "Review of Computer Networking Technology"
R. P. Blanc
January, 1974
NBS Technical Note No. 804
9. "Microeconomics and the Market for
Computer Services"
I. W. Cotton
Submitted for publication
10. "Cost Analyses for Computer Communications"
R. P. Blanc
NBS Report In Preparation
11. "Network User Information Support"
A. J. Neumann
NBS Technical Note No. 802
Expected Publication: February 1974
12. "Quality Service Assurance Experiments"
R. Stillman
January, 1974
NBS Technical Note No. 800
13. "A Guide to Networking Terminology"
A. J. Neumann
NBS Technical Note No. 803
Expected Publication: February 1974
14. "Research Considerations In Computer Networking"
D. W. Fife
NBS Technical Note No. 801
Expected Publication: February 1974

CONTENTS

	Page
Introduction	1
ARPA Network	4
MERIT Network	22
Triangle Universities Computation Center	34
Oregon State Regional Network	51
TYMNET	61
Conclusions	71

Acknowledgements

The contributions to this document of Robert Blanc, Albrecht Neumann, Dennis Fife and Thomas Pyke, Jr., all of the Institute for Computer Sciences and Technology, are expressly and gratefully acknowledged. Also, the assistance of technical and managerial personnel from each of the networks surveyed, both in providing information and in reviewing drafts, is noted and appreciated. Of course, the ultimate responsibility for the content of this document is the author's alone.

Network Management Survey

Ira W. Cotton

This report presents the results of a study of management practices in different computer networks. Five networks were chosen as typical of different approaches to network implementation and management: Defense Advanced Research Projects Agency (ARPA) Network, MERIT Network, Triangle Universities Computation Center (TUCC), Oregon State Regional Network and Tymnet, a commercial network. A common format is employed to survey each network. While the report is not intended to be prescriptive, some empirical observations are presented for each topic covered.

Key words: Computer network; management;
network; network management

Introduction

This report on management practices in different computer networks presents some of the results of a study conducted by the Institute for Computer Sciences and Technology, National Bureau of Standards, for the National Science Foundation in support of the "Networking for Science" program. The approach to management taken in this report is positive (i.e., reporting on current practices as they exist); the normative or prescriptive approach is taken in a separate report as indicated in the foreword.

This survey is meant to be representative and illustrative rather than exhaustive or conclusive. The networks covered were chosen to be typical of different approaches to network implementation and management.

The ARPA network is a large distributed network of autonomous, heterogeneous computer systems. It has focused on the development of network technology and resource-sharing techniques, rather than organizational problems.

MERIT is a controlled experiment in networking on a regional basis with heterogeneous computer systems. Considerable attention has been focused during the network's development on the organizational problems.

TUCC is another regional network, but with homogeneous computers and a larger number of participating institutions. TUCC has also given considerable attention to organizational issues.

The Oregon State network is representative of many centralized or "star" networks serving a regional clientele.

TYMNET is the only commercial network included in the study. It was desired to include a profit-seeking network in the study, so as to be able to compare managerial practices in non-competitive environments with actual business practices. (Of course, the inclusion of TYMNET in this study in no way implies endorsement of this network).

Information for this report was gathered from primary and secondary literature sources, from telephone and on-site interviews, and by iterative review of this document by representatives of the networks covered. In some cases the information presented here will already be out of date by the time this report is published, so rapidly are these networks developing.

A common format was employed for presenting the details of each network. The table of contents which follows is an outline for each of the five surveys which follow it. Network architecture is separated from network management, and the latter is broken down into a number of different functional areas. This approach was adopted to permit easy comparison of specific managerial concerns from network to network. Some empirical observations from such comparisons are presented in a concluding section which follows the same format as each of the reports.

Some comments are probably in order regarding the use of the term "successful" with reference to the networks surveyed. In the author's view, success is measured by the satisfaction and acceptance of the network and its facilities by its users. This should translate to the continued existence of the network, and in most cases to growth. Used in this sense, the term transcends mere technical accomplishments. A network which performs

adequately in the technical sense but which fails to satisfy user needs can not be considered successful.

Table 1. Organization of Each Survey

I. Introduction

II. Network Identification and General Description

- A. Sponsoring Organization
- B. Purpose/mission of Network
- C. Status and Topology
- D. Technology Summary
- E. Future Plans

III. Network Organization

- A. Structure and Extent
- B. Functions Performed
 - 1. Planning
 - 2. Installation
 - 3. Operations
 - 4. User Services
- C. Interfaces (relationships with other organizations)

IV. Financial and Legal Concerns

- A. Capitalization
- B. Accounting
- C. Regulation
- D. Security

V. Conclusions

- A. Summary of Problems
- B. Lessons Learned

Annexes

- A. Bibliography
- B. Special Vocabulary

ARPA Network

I. Introduction

The ARPA Network is characteristic of large decentralized networks of autonomous computer systems. Its continued successful operation has been widely publicized in the professional literature and trade press, and has demonstrated the technical feasibility of packet-switching for large networks.

II. Network Identification and General Description

A. Sponsoring Organization

The network is sponsored by the Defense Advanced Research Projects Agency (ARPA), an agency of the Department of Defense concerned with research and development in areas of advanced technology.

B. Purpose/mission of Network

The ARPA Network was begun as a research effort to investigate multiple computer resource sharing and to demonstrate the feasibility of packet switching technology.

The network currently supports many ARPA-sponsored research programs by providing access to resources not available locally.

C. Status and Topology

The network has been operational since mid-1971. Figures 1 and 2 illustrate respectively the recent geography and topology of the network. The network currently includes over 30 sites with over 40 independent computer systems connected.

Reliability of the various network components varies widely. Currently the communications subnet of Interface Message Processors (IMPs) and circuits has extremely high reliability, with only occasional outages for particular IMPs or circuits. Since most nodes are connected to at least two other nodes, the outage of a single circuit does not disturb network operation. The service sites are generally less reliable than the subnet, although the statistics vary widely from site to site.

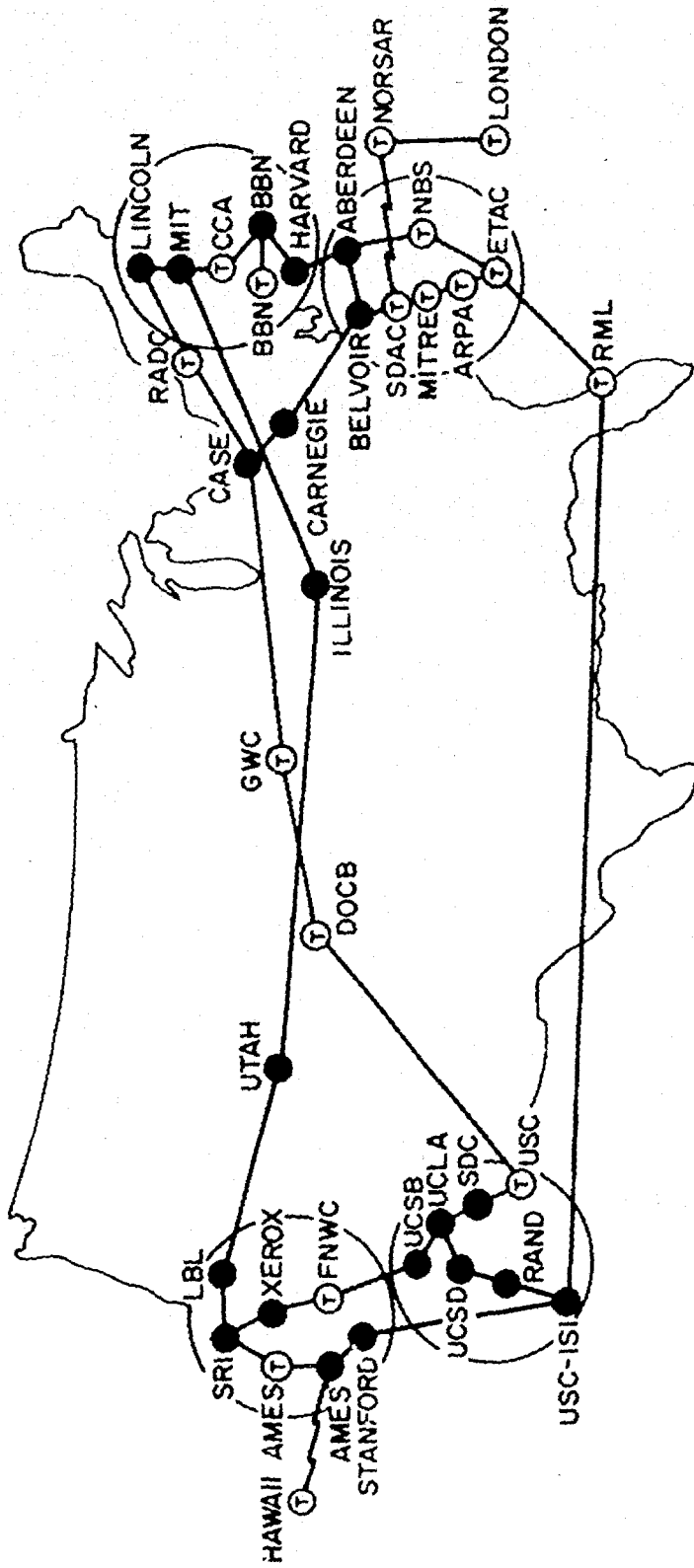

FIGURE 1 ARPANET NETWORK, GEOGRAPHIC MAP, SEPTEMBER 1973

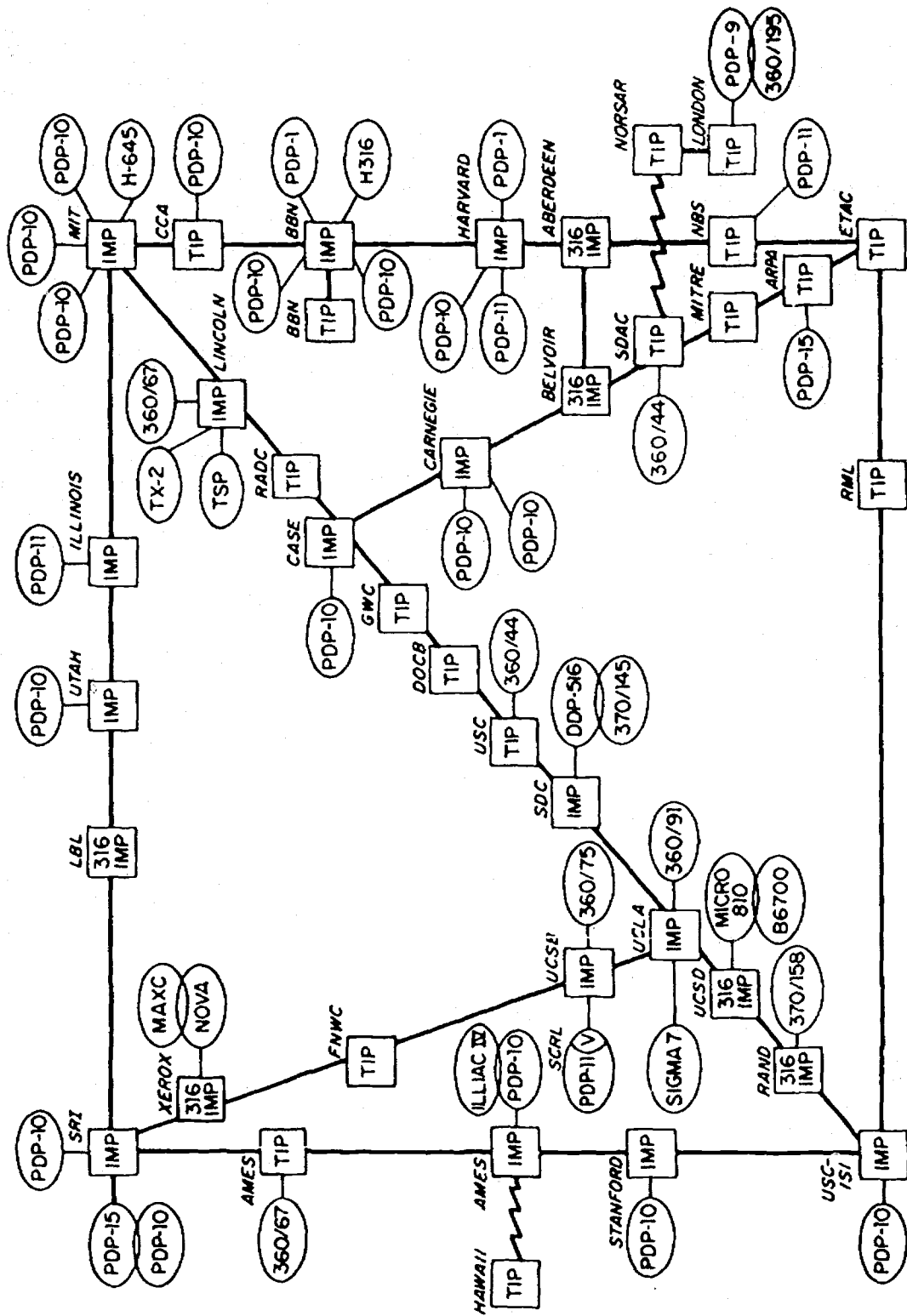

FIGURE 2 ARPA NETWORK, LOGICAL MAP, SEPTEMBER 1973



D. Technology Summary

The ARPA Network may be characterized as a distributed store-and-forward network of heterogeneous computer systems (hosts). Hosts are connected to the communications subnet by means of a software interface called the Network Control Program (NCP) and a hardware interface which may have the characteristics of either a channel or a communications line. Each host is connected to a switching center in the subnet called an Interface Message Processor (IMP) which contains an augmented Honeywell 516 or 316 computer; up to four independent hosts may be connected to the same IMP. Each IMP is connected to two or more neighboring IMPs by means of dedicated 50kb communications lines. Host to host messages are passed from the sending host to its IMP, where they are broken into packets and relayed to their destination by the subnetwork of IMPs and communications lines. The routing is adaptive; i.e., the route of any given packet is not established in advance and in general the several packets of a message may follow different routes. The destination IMP will reassemble the message and deliver it to the proper host.

Protocols in the network are constructed according to a layered approach. The lowest level protocol is a binary synchronous communications protocol governing traffic exchange between IMPs. The so-called "first level" protocol governs the logical exchange of information between host and IMP. The "second level" protocol governs the logical exchange of information between Network Control Programs in communicating hosts. The "third level" of protocol refers to any communications occurring between processes in the host machines. Such third level protocols include the Initial Connection Protocol (ICP), data transfer protocol, file transfer protocol, remote job entry protocol, graphics protocol, and others.

A special third level protocol called TELNET defines a network virtual terminal and permits all terminals on the network to provide a similar interface to processes in a separate host computer system. A special IMP which is augmented by the addition of memory and a multiline controller (a

specially designed component containing central logic and line interface units) can provide direct network access to terminals without going through a separate host computer system by providing the TELNET function itself. Such an IMP is called a Terminal IMP, or TIP.

E. Future Plans

The ARPA network continues to grow at a rate of about one site per month. It has been extended into Hawaii and Europe via satellite links. Network traffic has been growing at an exponential rate for some time. The main technical work includes redesign of the present IMPs, development of mini-computer front ends to IMPs for remote job entry and private line interfaces, and the continued refinement of the protocols. Organizationally, the network is turning its attention to improving resource-sharing facilities.

III. Network Organization

A. Structure and Extent

Figure 3 illustrates the present organizational structure for the network.

The Advanced Research Projects Agency (ARPA) of the Department of Defense initially conceived and funded the network, and presently directs its operation through the Information Processing Techniques Directorate. ARPA is not a large agency, serving primarily as a granting agency, and only several people spend their full time on network activities.

ARPA has turned over the day-to-day operation of the communications network to the USAF Range Measurements Laboratory (RML) at Patrick AFB in Florida. RML will serve as the procurement agent for IMPs and maintenance services and as the central liaison point for the Defense Commercial Communications Office and the common carriers (see below, III-B-1), Bolt Beranek and Newman, Network Analysis Corporation, and prospective new users.

Bolt Beranek and Newman (BBN) of Cambridge, Massachusetts, is the primary ARPA contractor in

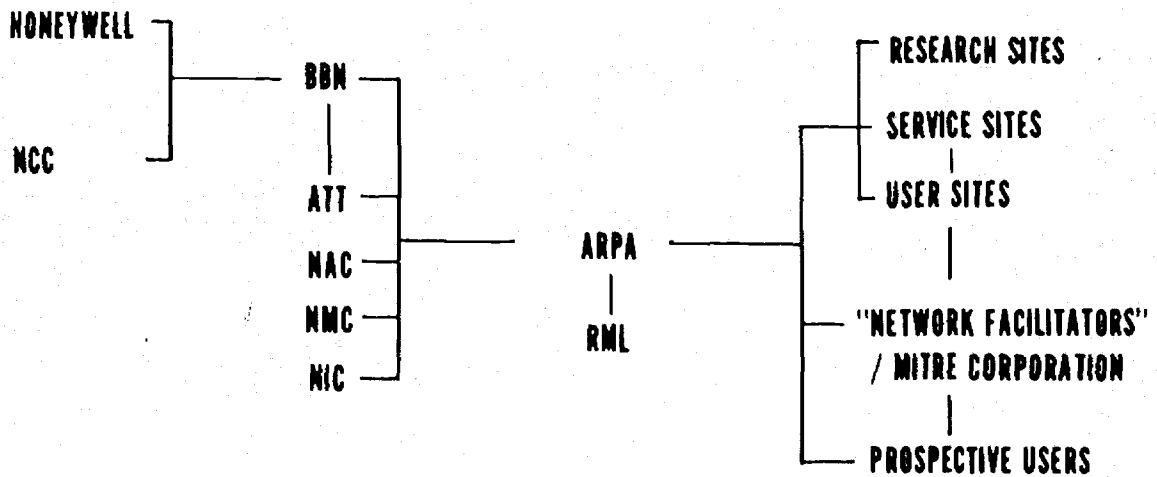

- BBN- Bolt Beranek & Newman**
- ATT- American Telephone & Telegraph**
- NAC- Network Analysis Corporation**
- NMC- Network Measurement Center (at UCLA)**
- NIC- Network Information Center (at SRI)**
- NCC- Network Control Center (at BBN)**
- RML- Range Measurements Laboratory (Patrick AFB)**

Figure 3. Present Organizational Structure for Operation of the ARPA Network

the development and operation of the network. BBN designed and constructed the IMPs and TIPS which comprise the subnet, wrote the software for these processors, and participated in the specification of the network protocols. BBN currently oversees all network modifications, dealing, through RML, with the Bell System for the wideband circuits, and with Honeywell Information Systems for the procurement of H-516 and H-316 processors for inclusion in the IMPs and TIPS. BBN also operates a Network Control Center (NCC) which monitors the operation of the network on a round-the-clock basis and which aids in the diagnosis of failures and initiates and coordinates maintenance efforts.

Honeywell Information Systems is an OEM supplier of basic H-316 and H-516 processors, from which BBN fabricates the IMPs and TIPS. Honeywell field engineers also assist in the installation of the IMPs and TIPS, and are responsible for maintenance.

Network Analysis Corporation (NAC), Glen Cove, N.Y., serves as an ARPA contractor for analytical studies to determine the optimum topology of the network and select the topology actually used.

The Network Measurement Center (NMC) is an ARPA-supported research group at the University of California (Los Angeles) which performs measurements and investigates the performance of the network.

The Network Information Center (NIC) at Stanford Research Institute provides a reference center serving to receive, record, index, and transmit, online and offline, information produced by and about the Network. To do this it designs information-handling tools for dialogue and record-handling. The NIC currently operates a PDP-10 TENEX system which is used both for development and network services. However, it is planned to separate the development activities from the service functions through an arrangement with Tymshare, Inc. The involvement with Tymshare is strictly on a "facilities management" basis. That is, Tymshare will operate a computer system virtually identical to the one at the NIC, to provide reliable Tenex, NLS, and Journal service to NIC users and other selected customers. The NIC

staff will remain at SRI, as will the responsibility for further developments in these areas.

Approximately 18 hosts may be classified as research sites. These sites perform research in a number of areas under ARPA contracts and utilize the network in support of their research.

Six sites are classified as service sites: UCLA (360/91), SRI (NIC), UCSB (360/75), BBN (PDP-10), USC-ISI (PDP-10) and MIT (MULTICS). Some of these sites offer services to the network community on a fee basis; others are subsidized by ARPA.

The remaining sites are users, although intersite arrangements are often made for the sharing of resources. Almost all of the sites make some of their resources available, but not all guarantee to interact as a service organization. Each site has a Technical Liaison to answer technical questions, and a Station Agent to handle questions concerning administrative, documentation, and similar questions regarding the network resources and the NIC.

The "network facilitators" were an informal committee of experienced users who proselytized and attempted to solve network problems for users. This group was in existence for about a year, after which it disappeared. The performance of this type of function has since been delegated to a group at the Mitre Corporation under contract to ARPA. Mitre publishes a network newsletter, responds to user inquiries and provides various kinds of assistance.

Other groups that are in a sense "network facilitators" are these special and general interest groups:

- ANTS Support Group
- ARPANET Satellite System
- Computer Based Instruction Group
- File Transfer Protocol Interest Group
- Imlac Interest Group
- International Network Working Group
- International Packet Network Working Group
- Network Associates Group

Network Graphics Group
Network Information Center
Network Liaison Group
Network Measurement Group
Network Station Agent Group
Network Working Group Steering Committee
Principal Investigators
Packet Radio Group
Remote Job Entry
Speech Understanding Research Group
TIP Users Group
TNLS User Group
TENEX Users Group

B. Functions Performed

1. Planning

Network growth is controlled by the sponsoring agency, ARPA. However, Karp (1973) indicates that the first 15 sites were ARPA research facilities selected for their expertise in software and system design rather than for the computer resources they could provide. Subsequent sites have provided both additional resources and users of these resources. There does not appear to be any fixed or published policy for determining what sites are to be added. Network growth is presently limited by the rate at which Honeywell and BBN can supply IMPs (about 1 per month).

When a new site is selected, Network Analysis Corporation determines for ARPA the new topology for the subnet. The network topology is not optimized each time a node is added, since that might entail too costly and disruptive alterations of existing circuits, but the new node is added in as cost-effective a means as possible. Occasionally, more extensive changes are made to the network topology as needs warrant. The planning function is thus centralized and supported by appropriate analysis.

All hardware procurement for the network is controlled by ARPA; the individual sites are not involved. ARPA places orders (through RML) for IMPs and TIPs with BBN. Communications circuits

are ordered through the Defense Commercial Communications Office (DECCO) which deals with the various common carriers. As explained below, in practice BBN coordinates circuit installation with the carriers.

2. Installation

Each site which is added to the network is responsible for fabricating the interface to the IMP or TIP and for coding a network control program (NCP). Specifications for each are available from Bolt Beranek and Newman. The host organization is also responsible for site preparation (floor space, power, air conditioning, etc.) for the IMP, which will reside at the host's own location.

Bolt Beranek and Newman coordinates IMP Installation through the Network Control Center. The normal installation team consists of a BBN representative, the person from the local Honeywell office who will maintain the machine, possibly an additional person from the main Honeywell office, and telephone company personnel.

3. Operations

The local host organization is responsible for maintenance of its host processor, NCP and IMP Interface. The local Honeywell office will maintain the IMP itself. AT&T Long Lines Division is responsible for maintenance of the modems and communications circuits.

For diagnostic and control purposes, BBN operates a special host system in Cambridge, Massachusetts, which is called the Network Control Center. The NCC regularly receives status reports from all the IMPs in the network regarding the operational status of their communication circuits and their neighbouring IMPs. Special programmable debugging and fault isolation procedures (such as looping lines back into the same IMP) may be initiated remotely from the NCC. Fault isolation may or may not require the assistance of local host personnel.

The maintenance function, which may involve several organizations including the Bell System, Honeywell, BBN and the local host, appears complicated, but is handled efficiently. The Network Control Center is very effective in diagnosing failures and coordinating maintenance among the various groups involved.

The division of responsibility for software is similar to that for hardware. All IMP software is controlled by BBN and is currently loaded via the network itself. Host organizations are forbidden to modify the software in their IMPs.

Functional protocols are specified by committees of host, ARPA and contractor personnel. At the lower levels these are fairly well agreed upon and debugged, and hosts agree to abide by them. At the higher levels, the protocols are still evolving, and subsets of hosts often experiment with variants among themselves.

At the present time, all of the lower level protocols are sufficiently well defined and debugged as to be of little or no concern to the average user. The higher level protocols, or more precisely, the lack of generally accepted and debugged higher level protocols (for example, remote job entry) have and continue to be a major hindrance to increased network utilization. However, these problems are recognized and new and improved protocols are being constructed and tested by various contractors.

4. User Services

Users at one site seeking to utilize resources at another site are required to be familiar with the characteristics (log-on procedures, operating system commands, program conventions, etc.) of that site. Documentation is, in general, provided by the serving site according to its own conventions. Several organizations do exist, however, to help users access remote resources.

The Network Facilitators Group was an informal committee of experienced personnel at various

sites around the country who organized to promote network utilization. This informal group has since been replaced by a group at the Mitre Corporation who have an ARPA contract to assist network users.

The Network Information Center is operated by Stanford Research Institute to facilitate the collection and dissemination of data produced by and about the Network. The NIC maintains online files of data about the Sites and people on the Network, maintains online tools for access to the data, and produces offline notebooks, indexes and directories of the data for use by the Network and other networking agencies. The NIC also functions to reproduce, catalog, index and distribute online and hardcopy documents as requested by Network Sites in the process of building and using the Network.

The user support function is probably the least well-provided function in the ARPA network. The quality of documentation and the general availability of assistance from sites varies tremendously from site to site. The network facilitators helped at selected user sites, but because of the informality of their organization and because they were not located at all sites they were not a general solution. Mitre has been at work on their user assistance task for too brief a period to be evaluated. The NIC has not provided a general solution to the documentation problem, since they do not attempt to distribute all the documentation needed to run at a particular site nor to enforce any documentation standards.

C. Interfaces (relationships with other organizations)

The question of the ARPA network's future status has yet to be settled. The network is a closed community, available only to governmental agencies and their contractors, but the network has been connected for demonstration purposes to other (commercial) networks (e.g., TYMNET). The ARPA network is presently functioning as a marketplace for the sale of computer time to the network community.

ARPA has indicated on several occasions that it does not intend to operate the network indefinitely and has already turned over daily operation to another governmental organization (RML). Various options for converting the network to commercial operation have been considered, but none have been considered feasible. It remains to be seen what the future of the network will be.

In another vein, the technology developed for the network has already received commercial attention. Several companies have filed applications with the Federal Communications Commission to set up and operate similar networks as common carriers (in some cases, using basic communications circuits provided by other common carriers in a so-called "value-added" configuration).

Finally, ARPA does seem interested in investigating the means and the difficulties of connecting to other networks. Many members of the ARPANET community participate in the International Network Working Group, originally an ARPA-sponsored initiative which is now a working group under IFIP with international participation. The purpose of the group is to develop inter-network protocols and to mount some international experiments.

IV. Financial and Legal Concerns

A. Capitalization

The network was funded by ARPA, so capitalization is provided through research grants. ARPA continues to subsidize the subnet communications circuits. Each of the IMPs and TIPS was either paid for by ARPA or the participating host organization. In general, some of the early sites were ARPA contractors, and so had their IMPs provided, while many of the newer sites are users who are paying for their own.

B. Accounting

Participation in the network requires access to the communications subnet and access to individual hosts on the network. IMPs and TIPS are available for a fixed fee from ARPA, which obtains them from BBN. Monthly maintenance charges must be paid

after the first year of operation. Communications charges are assessed by ARPA according to usage: a base fee plus a variable fee for traffic above a given minimum. In fact, most network participants have been supported by ARPA in one way or another, and communications costs continue to be subsidized.

Accounting for resources at the host sites is done by each of the hosts concerned. Each user who desires to utilize remote resources must open an account at the appropriate site. The friendliness of sites to external users varies considerably, as do billing rates. Billing procedures vary widely (some sites have been known to close an account when it ran out of funds without notifying the user) and require using sites to deal with many vendors. The overall situation is recognized to be less than satisfactory, and a committee of principal investigators is currently trying to develop a network-wide accounting scheme.

C. Regulation

No commercial users or non-research commercial servers are currently permitted on the network. As a research activity sponsored by the Department of Defense, the network is not subject to regulation by other government agencies (e.g., the FCC).

The wideband communications circuits used in the subnet are leased by ARPA through the Defense Department at bulk (TELPak D) rates. These rates represent considerable economies of scale for large data communications users.

D. Security

The communications subnet will insure that messages are delivered to the proper host. The non-deterministic routing of the individual packets of a message could be viewed as providing some degree of security to the subnet. At that point it is the responsibility of the host to insure delivery to the proper user. There is no checking on the origin of messages to insure that they agree with the identification given in a log-on sequence.

File security is the responsibility of the individual hosts. Log-on procedures, keyword

access and the like are among the procedures employed by the various hosts as protective mechanisms.

V. Conclusions

A. Summary of Problems

Start-up Requirements - Fabrication of the IMP interface and coding of the Network Control Program have been major obstacles to new hosts joining the network. BBN has fabricated some interfaces, but prefers not to do so. This problem is expected to continue, as the character of sites joining the network changes from researcher to user. However, a mitigating factor may be the inventory of interfaces and NCPs which have already been constructed.

Cost - The question of cost is growing in importance as the network operation is examined by potential commercial suppliers and as the full costs become known. Published documentation on costs have thus far dealt mainly with the communications subnet. Even here, the costs may be distorted because published figures are derived from loading factors which have never been realized (although traffic has been growing at an exponential rate). Also, the cost of network access (an IMP or TIP) remains high (though lower cost replacements are currently under development). However, the most significant concern is that the cost of the subnet may not be the major network cost. Recent studies have shown that the overhead associated with the NCP may be substantially larger than was previously believed. Additional cost studies are indicated, as well as a reevaluation of the current protocol strategy with a view to reducing overhead.

Reliability - In contrast to the now high reliability of the subnet, the host sites, at which the real work is done, vary widely in reliability.

Heterogeneity - While some facilities (such as TELNET, network mail and file transfer protocol) have been provided to permit common operation on hosts of different types, the problem has not been solved in general. Executive level commands are

all different for different machines, text editors are different, log-on procedures are different, etc. This is a difficulty which networks have only exacerbated by making additional systems available to potential users.

User Services - The need for readable, accurate, complete and available documentation cannot be stressed too much. Of equal importance, however, is the occasional need for hand-holding. On-line tutorials may provide some relief, but personal assistance by knowledgeable and friendly personnel will never be completely replaced by documentation. The current level of these services on the ARPA network leaves room for improvement.

Protocols - Lack of particular protocols such as graphics and remote job entry has cut off potential usage in some cases. This problem will be resolved as these protocols become better developed and are made generally available.

B. Lessons Learned

In fairness, it must be recognized that the ARPA network began as an experiment in networking among research-oriented sites. It has achieved its objective of demonstrating the feasibility of the packet-switching approach. Large numbers of users depend on the network now for their day-to-day work. Many of the problems which have been identified have arisen as the network matured and the complexion of its participants changed from research-oriented to usage-oriented.

In general, the network has functioned best where there has been formal responsibility and organization, for example, at the Network Control Center. The less directed efforts have been correspondingly less successful, for example, the higher level protocol committees.

The network seems also to have been most useful in offering services when the differences between host systems have been bridged automatically by the network. For example, perhaps the most successful service has been the TELNET, which has permitted a wide range of terminals to operate more or less identically on many different host systems. The resources for which this

type of standardization has not been performed have been less successful in attracting wide utilization. Additional work in this area seems indicated.

Annexes

A. Bibliography

Carr, S., Crocker, S. and V. Cerf. "Host/host communication protocol in the ARPA network." SJCC, 1970, pp. 589-597.

Crocker, Stephen D. et. al. "Function-oriented protocols for the ARPA computer network." SJCC 1972, pp. 271-279.

Frank, Howard, Robert E. Kahn and Leonard Kleinrock. "Computer communications network design -- experience with theory and practice." SJCC. 1972, pp. 255-270.

Heart, Frank E. et. al. "The interface message processor for the ARPA computer network." SJCC 1970, pp. 551-567.

Kahn, Robert E. and William R. Crowther. "A study of the ARPA network design and performance." Bolt Beranek and Newman, Report No. 2161, August 1971.

Karp, Peggy M. "Origin, development and current status of the ARPA network." <Comcon73>, pp. 49-52.

McKenzie, Alexander A. et. al. "The network control center for the ARPA network." <Computer Communication - Impacts and Implications> (Proc. ICC), 1972, pp. 185-191.

Mimno, N. W., et. al. "Terminal access to the ARPA network: experience and improvements." <Comcon73>, pp. 39-43.

Network Analysis Corporation. "ARPANET: design, operation, management and performance." Report to Rome Air Development Center, April 1973.

Ornstein, S. M. et. al. "The terminal IMP for the ARPA computer network." SJCC 1972, pp. 243-254.

Roberts, Lawrence G. and Barry D. Wessler.
"Computer network development to achieve resource sharing." SJCC 1970, pp. 543-549.

B. Special Vocabulary

IMP - Interface Message Processor - A specially modified Honeywell 316 or 516 processor which serves as the communications computer in the network.

TIP - Terminal IMP - An IMP which is augmented by additional memory and a multiline controller. The TIP contains a network control program and a TELNET program within it to permit terminals to access the network directly through it.

Multiline Controller - A specially designed multiplexor-like device which supports the access of up to 64 terminals of varying type into a TIP.

Message - A logical unit of data exchange between processes.

Packet - Physical segments of a message which are the transmission units in the subnet.

Subnet - The array of IMPs, TIPs and communication circuits which deliver messages from one host to another.

MERIT Network

I. Introduction

The MERIT Network is representative of a controlled experiment in networking on a regional basis. The straightforward design of the communications system and the limited size of the network have permitted attention to be focused on the managerial problems of the network.

II. Network Identification and General Description

A. Sponsoring Organization

In 1966, Michigan State University, Wayne State University and the University of Michigan formally established a program of mutual cooperation known as MICIS (Michigan Interuniversity Committee on Information Systems). MICIS established a non-profit corporation, MERIT (Michigan Educational Research Triad, Inc.), for the purpose of receiving and distributing funds for research. It is this non-profit corporation which sponsors the network.

B. Purpose/mission of Network

The Merit Network is a prototype educational computing network that seeks to enhance the educational and computing resources of each university by permitting network participants to share resources. The objectives of the network were broadly stated as gaining, through the development and successful implementation of a network, knowledge about and solutions to the problems of network operation in an established educational computing environment.

The three computer systems in the network are sufficiently different as to make desirable the directing of particular types of work to one of them from the others.

The University of Michigan's system, using duplex IBM 360/67 hardware, was designed especially for timesharing using MTS.

The Michigan State University computer (CDC 6500) is unusually fast and therefore well-suited to large, compute-bound jobs.

The Wayne State University Computer Center, using duplex IBM 370/67 hardware running the MTS timesharing system, has developed a special competence in administrative data processing.

At the time of organization of the network, a cooperative policy in acquiring special peripheral equipment was considered feasible. It was suggested that relatively unusual equipment, such as a film recorder-scanner, might be purchased by one installation to serve all three universities.

C. Status and Topology

The network became operational in the summer of 1972. The topology of the network is three node, fully connected. Presently the network provides communication service, on a nearly continuous basis whenever the host systems are up; usage through 1973 has been light, however. Aupperle (1973) reports that current network-use data indicates that between one and two million bytes are transmitted monthly by an average of twenty individual users. About 100 different users have tried the network during the second half of 1972, the first six-month period of statistical data gathering.

D. Technology Summary

The three host systems in the MERIT network are tied together through small communications computers located at each host site, which are themselves interconnected by means of modems through the switched telephone network. The interface which the communications computers present to the host system are uniquely adapted to the requirements of each particular host; the interface which the communications computers present to the telephone network (and thus to each other) are identical. A somewhat novel capability is the ability to dynamically vary the bandwidth of the communications paths available between pairs of hosts. This is accomplished by providing each communications computer with four separate modems and an automatic calling unit. The bandwidth represented by the four lines may be allocated to communications with either of the other two hosts as dictated by immediate communications

requirements; normally at least one line is kept open to each other remote site.

The communications computer consists of a standard Digital Equipment Corporation PDP-11/20 with 16K words of 16-bit core memory. Four different types of interfaces are required:

1. Data set interface
2. Automatic calling unit and multiplexor interface
3. IBM 360/67 Interface (one for each of two host systems)
4. CDC 6500 Interface (for one host system)

The data set interfaces are designed to transfer entire messages over the telephone network directly to and from the PDP-11's core memory without program intervention, once the transfer is initialized by software action. These interfaces are designed to function as either half-duplex or full-duplex units over a wide range of frequencies and are compatible with binary synchronous communications procedures.

Automatic calling unit and multiplexor interfaces provide the communications computer with the ability to dial, under program control, a single telephone call. The automatic calling unit may be shared among eight telephone lines.

The host interfaces (IBM 360 and CDC 6500), like the data set interfaces, are designed to transfer entire messages without intervention, once appropriate action is initiated. The interfaces transfer data in parallel between the host and the communications computer, and they partially resolve the word length mismatch that exist between these machines. The host interfaces also cause the communications computer to appear as a number of identical, but separate, devices to the host, thus simplifying the logical structure of multiple user activity over the network and minimizing the amount of the host's network support software.

The systems programming requirements for the MERIT

computer network consist of device support for the communications computer in each of the hosts, and an operating system in the communications computer which provides support for the message switching function and an interface to each host. Each host treats the communications computer as an I/O device. Together, the software elements in the host and communications computers permit a user to establish a path to a remote host and to utilize services there. All terminal access into the network is through the local host; there is no direct terminal access into the network which bypasses the local host. However, this capability is being considered for future implementation.

E. Future Plans

The MERIT network continues to serve the three participating universities. There is consideration for a remote version of the communications computer to allow terminals to access the network directly (without there being a local host) so as to be able to offer service to other institutions in the region. Work is underway to extend the communications computer software to allow the routing of messages in a less-than-fully connected network.

III. Network Organization

A. Structure and Extent

Figure 1 presents a simplified view of the organization of the MERIT Computer Network.

The Michigan Interuniversity Committee on Information Systems (MICIS) is made up of representatives from each of the three participating universities. A few are computer experts, but most are not. MICIS members in turn are responsible for selecting the Director of the MERIT Computer Network.

The MERIT Computer Network project director is responsible for the orderly execution of all of the technical and contractual responsibilities, broadly divisible into three, staff supported functions:

1. Educational and promotional;

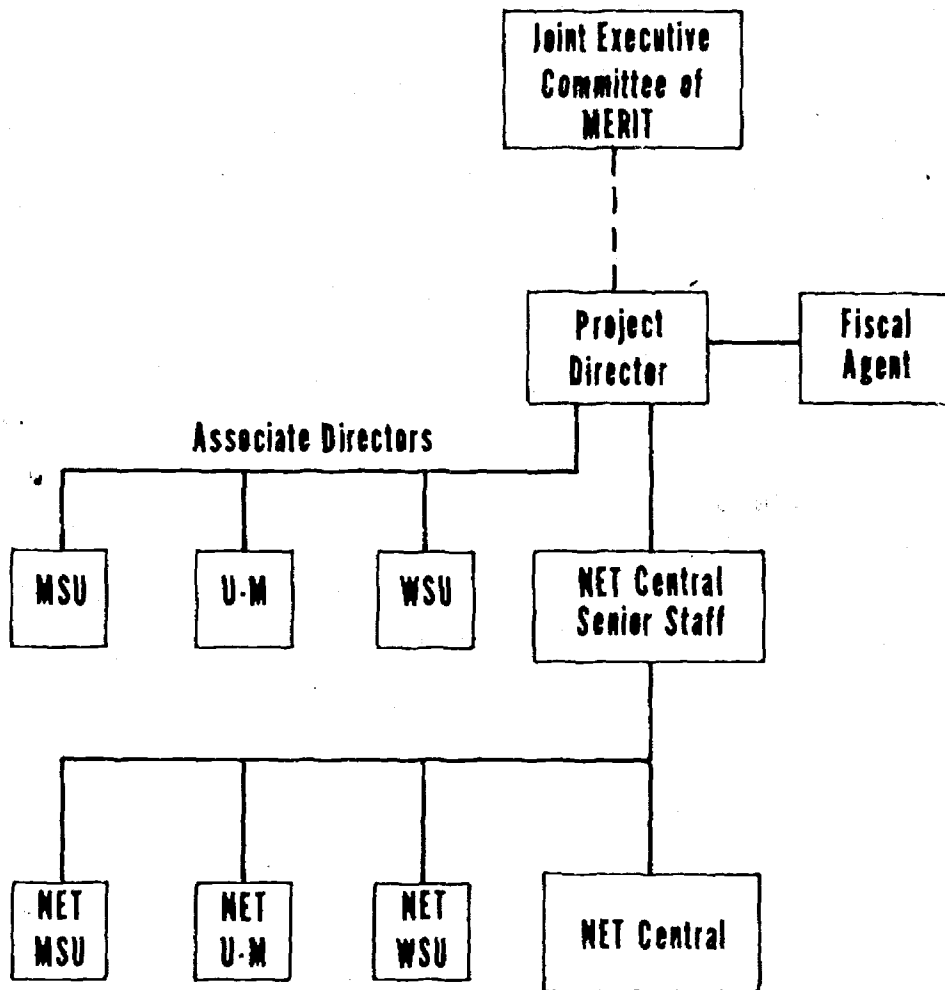

Figure 1. Simplified MERIT Computer Network Organization Chart

2. Research and technical development of the networks; and
3. Financial administration.

For the initial phase of network design and construction, MICIS chose a computer expert, Dr. Bertram Herzog, to lead the work. The director's office is located at the University of Michigan.

In the educational and promotional functions, the director is assisted by three associate directors, one located at each campus. The associate directors are chosen by the director from nominations made by the universities. The special responsibility of each associate director is to promote and encourage the development of the network within his own community of users. He has essentially a dual role: to support the director and the network so that the implementation of the network at his particular site proceeds as effectively as possible, and to insure that his own university's interests are equitably served with respect to the demands made on its resources by the network. The associate directors have no direct responsibility for the technical details of the project, but they are kept informed of relevant developments and provide advice.

Four groups are concerned with the technical research and development function: the Network Central Staff, and the separate Network-Michigan State University, Network-University of Michigan, and Network-Wayne State University staffs individually affiliated with their respective host sites. Further, the Network Central Staff has two components: the senior staff with technical responsibility for all of these groups, and the programming staff, charged with developing software for the common part of the network. At the peak of activities, approximately the equivalent of 12 full-time engineers and systems programmers were involved in this facet of the project. This number represents (equivalently) two systems programmers located at each of the three campus computing centers and six members of the Network Central Staff located at MERIT headquarters.

Wayne State University acts as fiscal agent for the

network, fulfilling such functions as the receipt of funds from several sources, the distribution of these funds to the various MERIT groups and vendors, and the preparation of all contractual and budgetary material.

B. Functions Performed

1. Planning

Long range planning responsibility rests with MICIS, which continues to function as a committee and currently meets on a bimonthly schedule. Each university has appointed several representatives, officially four, to MICIS for an indefinite term. The representatives from each university consist of one high-ranking member of each university's administration and of faculty members, usually including the computing center director and others interested in computer application areas.

In its efforts to develop a computer network, MICIS sought both state and federal support. A three-member Joint Executive Committee was established by the participating universities to administer any funds provided by the State of Michigan. Further, in the fall of 1966 the Michigan Educational Research and Information Triad (MERIT) Inc. was created with its three man Board of Directors, and charged with the responsibility to solicit and receive non-state funds for the network. Wayne State University was designated as the fiscal agent for all state and non-state funds.

Once funding was assured, a network research and development project was established and work began in July 1969. Initially designated the Tri-University Computer Network, it later became known as the MERIT Computer Network Project. Thus the director of the MERIT Computer Network Project submits budgets for approval to the Joint Executive Committee and the Board of Directors of MERIT, Inc. (the same three people serve on both boards) whereupon the fiscal agent executes the appropriate contractual operations.

2. Installation

The special communications facilities for the network were developed by the project staff under the guidance of the Director. This development included communications computer hardware and common software. Software specific to a particular site, and all software residing in the host computers, is the primary responsibility of each host site's staff. A common design for network software was developed by the central project staff.

The Associate Director at each of the participating universities is responsible for matters relating to the installation of the network facilities at his site.

3. Operations

Day-to-day management responsibility for the network rests with the Director and his staff.

The MERIT staff is developing procedures to closely monitor the performance of the network. Statistics gathered on message errors, traffic distribution, and overall throughput will significantly help in adapting the original network design to actual usage patterns.

4. User Services

Responsibility for promoting the network within each of the member universities and for providing the required user services rest with the associate directors.

The distribution of system documentation throughout the user community is the joint responsibility of MERIT and the individual universities. At the present time, MERIT disseminates information relevant to the design and operation of the communications subsystem and its interfaces. Each university is required to maintain and distribute its local facility's documentation and is responsible for issuing notices reflecting any significant changes.

C. Interfaces (relationships with other organizations)

As explained below, the MERIT network was funded by the Michigan State Legislature and the National Science Foundation. While this has not received much attention in the open literature, it is clear that the network will need to be responsive to the wishes of the Legislature. Along these lines, it is the intention of the network's developers to provide the capability for network access by many of the smaller colleges and universities in the State of Michigan without host computers.

IV. Financial and Legal Concerns

A. Capitalization

The Merit Computer Network was funded, initially for two years, by the Michigan State Legislature, the National Science Foundation and each of the participating universities. The Michigan State Legislature provided in successive appropriation bills the total sum of \$400,000, provided that matching support could be obtained from other sources. By the end of 1968, a proposal in the amount of \$400,000 was submitted to and subsequently funded by the National Science Foundation.

B. Accounting

The Director and the Joint Executive Committee of MERIT have focused much attention on the accounting difficulties encountered in even so controlled a network as this. The MERIT network follows the basic policy of permitting each site to set prices and charge for services individually. The problem is not in getting sites to offer resources for sale, but in convincing management at each of the sites to permit usage of resources at other sites. The problem is that the possible "balance of payments" deficit (excess of outside use by local users over inhouse use by outside users) cannot be predicted in advance, and therefore is very difficult to budget for, especially on a normal annual basis.

In MERIT's case, relief was sought and obtained from the universities' administrations to pledge,

from sources other than the computing budgets, an amount of monies to protect the potentially unbalanced budgets of the wholesaler (local university computer centers) due to the presence of the network. By so doing, a deterrent to utilization was removed.

C. Regulation

The MICIS and the MERIT efforts have been formally approved by the Michigan State Legislature, the State Board of Education, and the governing boards of each of the three universities.

Communications between sites in the MERIT Computer Network currently utilize a pre-existing, inter-university, voice-grade telephone network.

D. Security

No special security procedures have been developed for the MERIT network beyond the normal access control mechanisms for the individual host systems. However, all users of remote resources presently must be validated by their own system as well as the remote system, since there is no access to the network other than through a local host.

V. Conclusions

A. Summary of Problems

The developers of the MERIT network have had to face all the problems faced by developers of other networks of heterogeneous computers (e.g., ARPA). The most publicized problems have been in non-technical areas. However, the development of a processor which offers a common interface to the network from the specialized interface requirements of each host machine was a non-trivial effort. Similarly, the development of the necessary control software for each of the host systems had to be undertaken. By and large the major technical difficulties have been overcome, although some peculiarities remain to be ironed out. (For example, terminals behave according to the system to which they are physically connected, not the system which they may be using, as in the ARPA network).

Perhaps the most publicized non-technical issue in the MERIT network has been the budgeting problem: getting the computer centers of the three universities to budget for possible net deficits in network usage (excess of work sent to other nodes over work taken in) for a period greater than a single calendar year.

With this problem apparently solved (as explained in IV-8), the main problem has been insufficient network usage to justify its existence. It appears that the three participating universities each have sufficient computing resources to satisfy local needs, so that there are few compelling reasons for extensive use of the network. Also, the double charges for use of remote resources (charges by both the local and the remote system) tend to discourage network usage. This problem could be solved by the expansion of the network to include additional user-only and direct terminal-access sites in the state, as the network developers envisioned.

B. Lessons Learned

One important lesson to be learned from the MERIT experience is that organizational and managerial problems can frequently dominate technical problems in the development of a computer network, and can even cast a shadow on technically sound networks.

In the technical area, MERIT has provided additional evidence as to the soundness of using an intermediate communications computer to mediate between the standard operations of the network and the peculiarities of each host.

Annexes

A. Bibliography

Aupperle, Eric M. "Merit network re-examined." <Comcon 73>, pp. 25-30.

Becher, William D. "The communications computer hardware of the MERIT computer network." <IEEE Trans. on Communications>, Vol. COM-20, June 1972, pp. 516-526.

Cocanower, A. B. et. al. "The communications computer operating system -- the initial design." MERIT Computer Network Manual 1070-TN-3, October 1970 (PB 203 552).

Coleman, Susan (Ed.). "Users guide." (Preliminary). MERIT Computer Network publication MCN-0473-UM-11, April 1973.

Eick, Harry, Seymour J. Wolfson and Karl L. Zinn. "Facilities & resources available via the MERIT computing centers." MERIT Computer Network publication MCN-0573-GE-14, May 1973.

Herzog, Bertram. "MERIT proposal summary." MERIT Computer Network publication, February 1970.

Herzog, Bertram. "Computer networks." <Proc.> International Computing Symposium, 12-14 April 1973, CINI Foundation, Venice, Italy, pp. 182-199. (MERIT Computer Network Publication MCN-0572-TP-8, May 1972.)

Herzog, Bertram. "Progress report for the period July 1969-March 1971." MERIT Computer Network publication 0571-PR-4, May 1971.

B. Special Vocabulary

CC - Communications Computer, the PDP-11 based front-end computer which provides a common network interface for host systems.

MERIT - Michigan Educational Research Triad

MICIS - Michigan Interuniversity Committee on Information Systems

Triangle Universities Computation Center (TUCC)

I. Introduction

TUCC is an example of a successful cooperative venture in regional networking by independent and autonomous universities.

II. Network Identification and General Description

A. Sponsoring Organization

The Triangle Universities Computation Center is a not-for-profit corporation which is owned by the three universities who cooperatively sponsored its establishment -- Duke University at Durham, North Carolina State University at Raleigh and the University of North Carolina at Chapel Hill.

B. Purpose/Mission of Network

The network has three primary goals:

1. To provide each of the institutions with adequate computational facilities as economically as possible;
2. To minimize the number of systems programming personnel needed; and
3. To foster greater cooperation in the exchange of systems, programs and ideas among the three universities.

Services include educational, research and administrative computing services for the three major universities, about fifty smaller schools and several research laboratories.

C. Status and Topology

TUCC is essentially a centralized, homogeneous network comprising a central service node (IBM 370/165), three primary job source nodes (IBM 360/75, IBM 360/40, IBM 370/135), 23 secondary job source nodes (leased line Data 100s, UCC 1200s, IBM 1130s, IBM 2780s, and leased and dial line IBM 2770s) and about 125 tertiary job source nodes (64 dial or leased lines for Teletype 33 ASRs, IBM 1050s, UCC 1035s, etc.). Figures 1 and 2

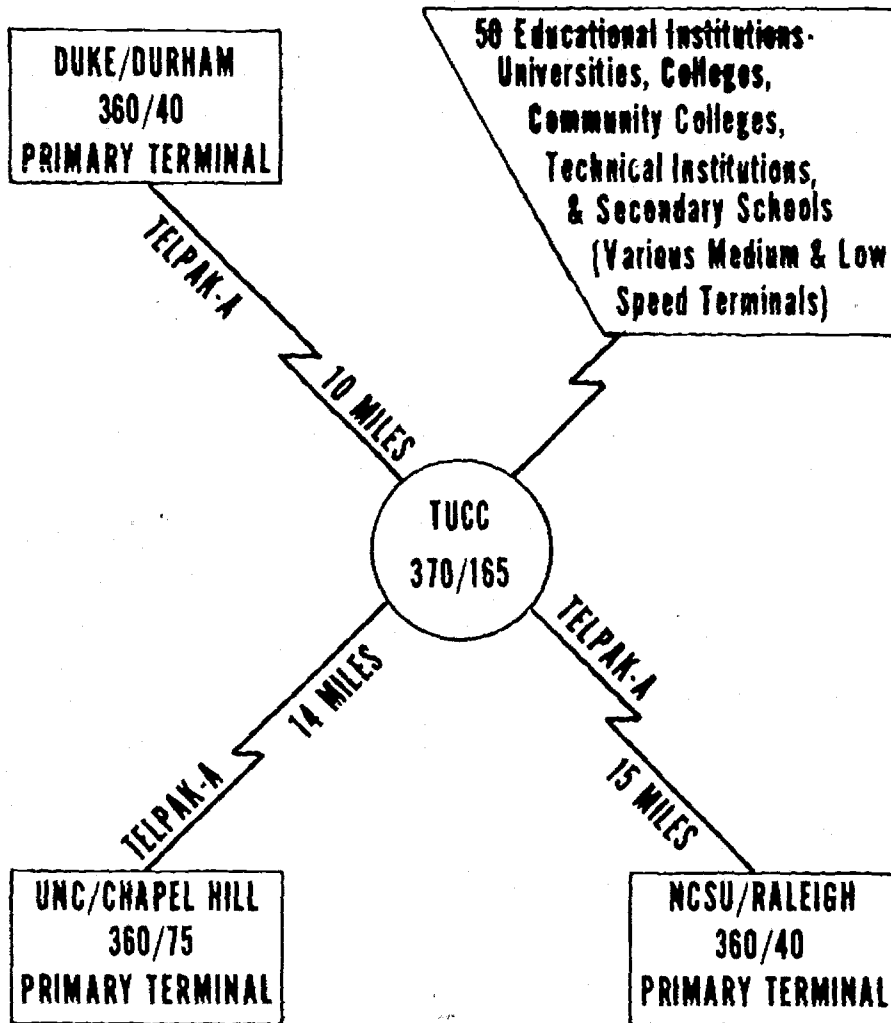

Note: In addition to the primary terminal installation at DUKE, UNC, and NCSU, each campus has an array of medium and low-speed terminals directly connected to TUCC.

Figure 1. The Tucc Network

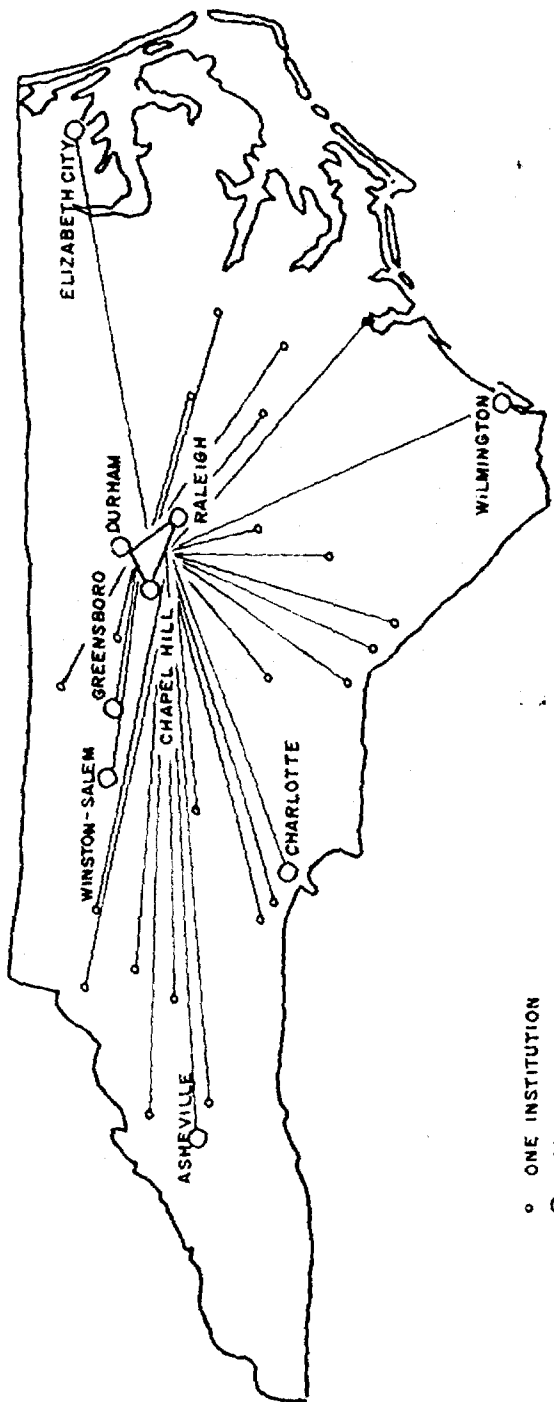

○ ONE INSTITUTION
 ○ MORE THAN ONE INSTITUTION
 IN ONE LOCATION

TOTAL NETWORK INSTITUTIONS: 53

ASHEVILLE	2
CHARLOTTE	2 (HIGHER EDUCATION)
DURHAM	10 (SECONDARY SCHOOL SYSTEM)
ELIZABETH CITY	3
GREENSBORO	2
RALEIGH	4
WINSTON-SALEM	3
WILMINGTON	3

Figure 2. Network of Institutions Served by TUCC/NCCECS

Illustrate respectively the topology and geography of the network.

Services to the TUCC user community include both remote job entry (RJE) and interactive processing. Thruput has grown from about 10,000 jobs per month in 1967 to about 80,000 jobs per month in 1972. (This increase in thruput was accomplished by hardware upgrades during the period). At the present time about 8000 different individual users are being served directly.

D. Technology Summary

TUCC operates a 3-megabyte, telecommunications-oriented IBM 370/165 using OS/360-MVT/HASP and supporting a wide variety of terminals (see Figure 3).

The three universities are connected to the TUCC by means of Telpak A (40.8 K baud) circuits which connect the universities' primary remote batch terminals to the central facility. In addition, over 50 educational institutions are linked to TUCC by a variety of medium and low speed lines which cover the state and extend as far as Elizabeth City, Wilmington and Ashville.

All local node computers are of the same manufacture as the central facility, and provide local computing services and teleprocessing services (from the central facility). Except in special circumstances, none of the local nodes provide computing services for remote users at this time, but the Hasp-to-Hasp software in use allows for such services to be provided if and when desired.

E. Future Plans

TUCC continues to serve its participating institutions. Hardware and software adjustments are made as required to insure adequate capacity to meet their processing demand. Immediate emphasis is on improving interactive services (primarily but not exclusively via TSO) and services for large data base processing including university administrative data processing.

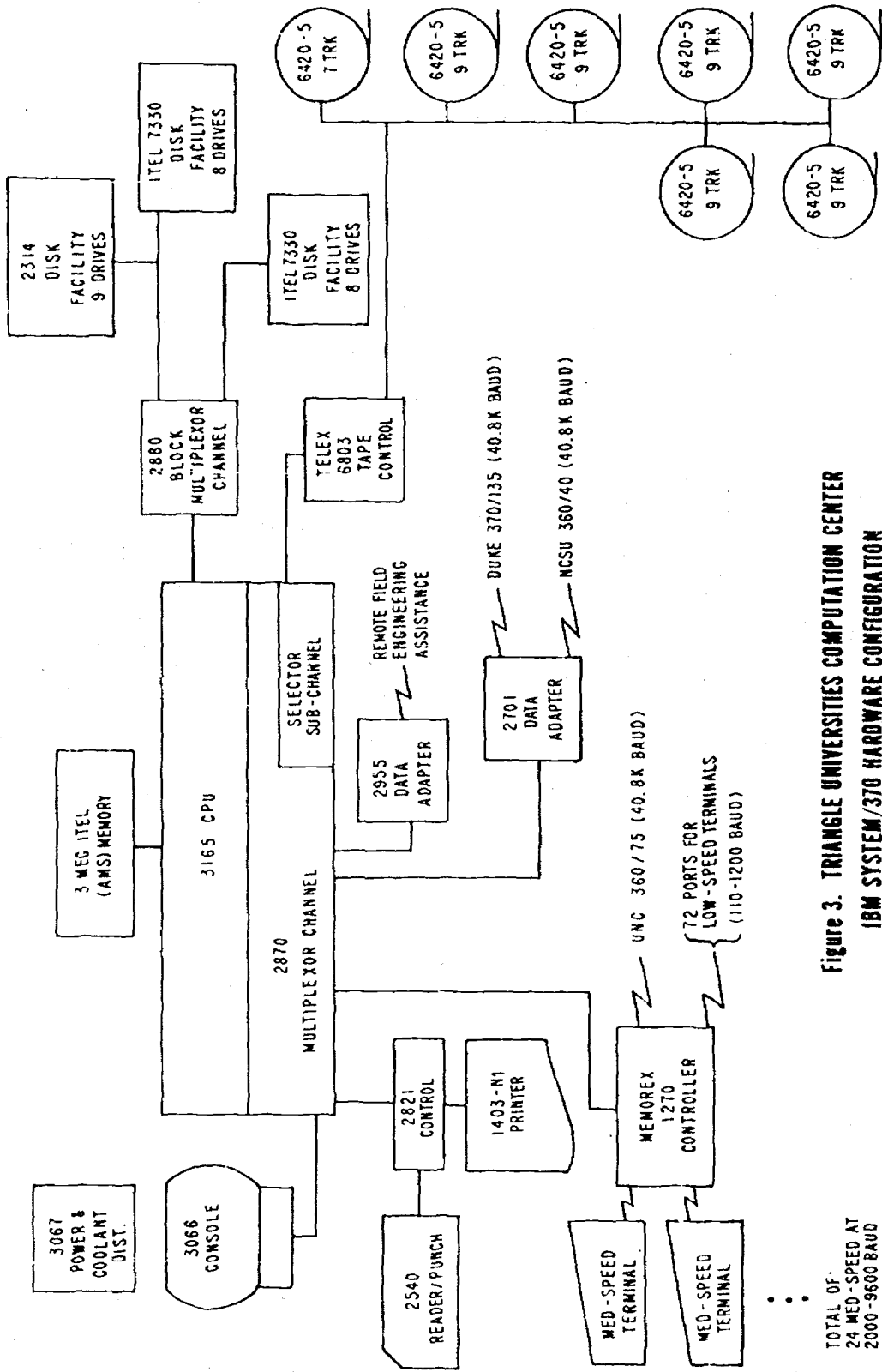

Figure 3. TRIANGLE UNIVERSITIES COMPUTATION CENTER
IBM SYSTEM/370 HARDWARE CONFIGURATION

TOTAL OF:
24 MED-SPEED AT
2000-9600 BAUD

III. Network Organization

A. Structure and Extent

The network is characterized by an organization which provides both for centralization of certain functions and the retention of freedom and authority by the individual computing centers to operate in the academic environment.

TUCC Organization

The TUCC Corporation is governed by a board of directors whose nine members represent the three major universities. The three members from each university represent the administration, computer science instruction and computer users. The board members are appointed by the executive officers of each institution. The board meets once a month to act on matters of general policy. Other attendees to board meetings are the President and Director of TUCC, the Associate Director and System Manager, the Campus Computation Center directors and the Director of NCECS (see section C below). Most questions are decided by simple majority vote of the board, except that questions of "fundamental importance" are decided by each university delegation casting a single vote. Questions of "fundamental importance" include selection of the TUCC President, the annual budget and major equipment decisions.

TUCC Staff

The central staff organization is shown in figure 4.

Systems Programming Section

This section is responsible for development, testing, integration and implementation of all TUCC and manufacturers' system software. The section is headed by a systems manager who is also the primary technical liaison between the campus computation centers and the manufacturers' field and systems engineering organization. The systems

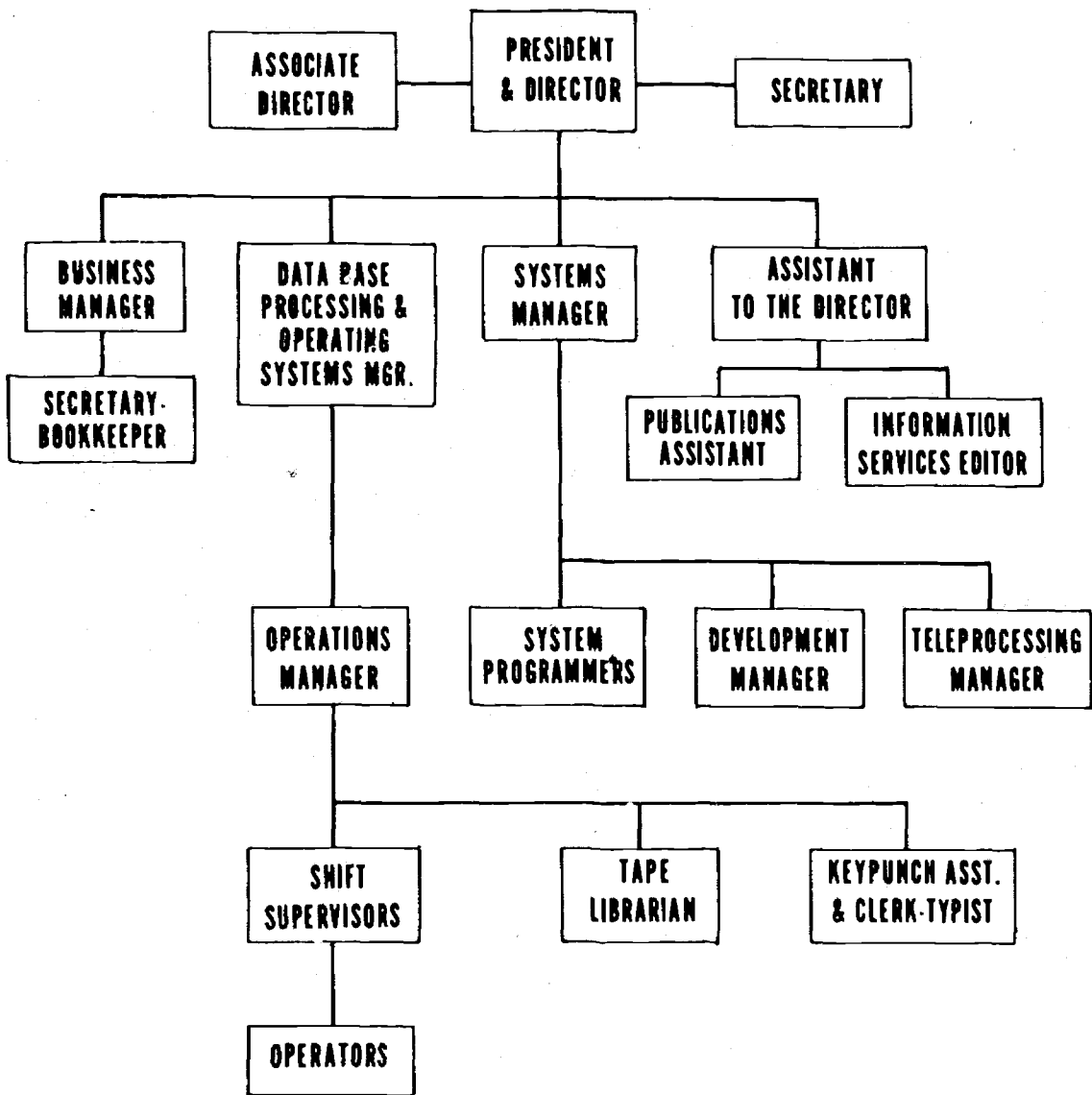

Figure 4. TUCS Organization Chart

manager serves as an Associate Director of TUCC.

Information Services Section

This group is responsible for the collection and dissemination of documentation to users, campus center staff, directors and the Board of Directors. Most documents are prepared throughout the network organization, including the documentation services section. These documents are edited, approved and published by this section. The section is also responsible for maintaining the program library, for documentation standards, for public relations and visitor liaison, for a periodic newsletter and for general interest brochures.

Development Section

This group is concerned with generation of new versions of the operating system, maintenance of the manufacturer supplied operating system, designing and programming of software interfaces between TUCC-written programs and the operating system, and creation of utility programs needed in the TUCC environment. The group is also responsible for design, programming and installation of monitors, statistics gathering programs for performance evaluation, and for the evaluation of overall systems performance.

Teleprocessing Section

The primary responsibility of this section is maintenance of the teleprocessing software. It maintains current knowledge of all terminals and plans and acquires new communications hardware as required. The teleprocessing manager also acts as a consultant to the campus centers and to individual users.

Operations Section

This section is concerned with the day-by-day

operations of the computer room. It also maintains the systems accounting records and prepares programs on systems usage, efficiency and turnaround statistics. It provides liaison with manufacturers' field engineers and with the campus computation center operations managers. It is also responsible for security.

B. Functions Performed

1. Planning

Once per month the campus computer center directors meet with the TUCC director, systems manager, and assistant director, primarily to discuss operational policies and procedures. Charging policies and changes to the billing algorithm are among the topics determined at the directors' meeting.

The TUCC systems manager and the systems programmers of the central staff and of the universities meet monthly to discuss plans for new systems additions and/or modifications.

2. Installation

As described in III.A above, all planning and control over equipment installation at TUCC is performed by the central management. Each university's computer center management performs these functions for its own center.

3. Operations

Each university computer center is autonomous and is operated by its own staff. TUCC is operated by a separate staff reporting to the central management.

4. User Services

Considerable attention has been devoted throughout the TUCC organization to the provision of adequate user services. Although there is some information dissemination from the central organization in the form of regular newsletters and an extensive documentation

system, the wholesaler-retailer organization insures that most user services are provided by the local computer center. This facilitates user access to these services and insures responsiveness on the part of the providers.

In the case of the small institutions served by NCECS, these services are provided by "circuit riders" who visit the schools on a regular basis. Schools are visited as needed and geographically close visits are usually coordinated. Consulting services are assisted by in-WATS telephone lines and personal contacts of remote users at workshops or through visits to the central facility. Data lines can also be used for voice transmission when not otherwise in use. Some use is being made of inquiries being sent by terminal communications to the central computer to be answered by the central staff.

C. Interfaces (relationships with other organizations)

The North Carolina Educational Computing Service (NCECS) was created as a state agency by the Board of Higher Education in 1969. (NCECS is the successor of the North Carolina Computer Orientation Project (NCCOP) which began in 1966). Its mission is to provide educational services to institutions throughout the state. NCECS provides technical support and consulting to small users. This includes computing services (terminals, communications and computer time) as well as technical support (information services, technical assistance to users, specialized software and documentation).

The director of NCECS represents his organization at TUCC board meetings in a non-voting capacity, and also attends meetings of the computer center directors. Close geographic co-location (in different wings of the same building) help intercommunications between the two staffs, although the organizations are totally independent.

The NCECS staff includes both state supported and project supported positions. Nine positions are state supported: the director, his secretary, administrative assistant for curriculum

development, manager of user services, three computing consultants, an information services officer and a business officer. Grant supported positions include curriculum development manager, programmer for curriculum development (half-time) and systems programmer (half-time).

The main function of the staff is the increase and improvement of involvement of the participating schools in computing. Two full time and one half-time "circuit riders" and a manager of user services deal directly with the needs of the outlying institutions, as explained above (III-8-4).

IV. Financial and Legal Concerns

A. Capitalization

Initial grants were received from NSF and from the North Carolina Board of Science and Technology, in whose Research Triangle Park building TUCC was located. These funds, along with the payments for services from the founding universities, served to establish TUCC.

B. Accounting

The accounting system for TUCC is based on a wholesaler-retailer concept. TUCC is a wholesaler of computing services, including machine cycles, operating system, programming languages and application programs, a documentation service, and management. The TUCC wholesale service specifically does not include typical user services -- debugging, contract programming, etc. -- nor does it include user level billing or curriculum development. Rather, these services are provided for their constituents by the campus computation centers and NCECS, which are retailers for the TUCC Network.

The wholesaler-retailer concept can also be seen in the financial and service relationships. Every two years the founding universities negotiate with each other and with TUCC to establish a minimum financial commitment from each to the net budgeted TUCC costs. Then, on an annual basis the founding universities and TUCC negotiate to establish the

TUCC machine configuration, each university's computing resource share, and the cost to each university. This negotiation includes adoption of an operating budget. Computing resource shares are stated as a percentage of the total resource each day.

Each of the three universities and NCECS currently pay 25% of the TUCC budgeted operating costs and are each entitled to equal amounts of service. A scheduling algorithm with a "usage leveling capability" allocates resources to the institution which has used the least so far. Each institution funds its own computer facility and communications lines. Each institution bills local users based on all of its costs, including payments made to TUCC, and on detailed usage statistics collected at the central computer.

The budget negotiation described above results in an effective wholesale rate to the three universities which is a little lower than the wholesale rate charged to NCECS. The justification for this procedure is the fact that the income from the universities is guaranteed while the income from the NCECS is less certain. Both the computing centers and the NCECS levy additional charges on the local user to cover local computing center costs and the costs of the additional NCECS central staff.

C. Regulation

No direct Federal or state regulations apply to the TUCC network. However, the state of North Carolina can exert influence over the network through the University of North Carolina.

Since the TUCC network does not extend outside the state of North Carolina except for occasional dial services, intrastate tariffs apply for most communications facilities. Standard telephone company services are utilized for wideband and voice grade circuits.

D. Security

In addition to those measures normally found in a third-generation operating system for the control

of access to files, TUCC has implemented its own data set and volume password systems as well as locally developed encrypting programs and operator procedures.

V. Conclusions

A. Summary of Problems

Administrative Data Processing

TUCC has for some time been handling the full range of administrative data processing for two NCECS universities and is beginning to do so for other NCECS schools. The primary reason that this application lags behind instructional applications in the NCECS schools is simply that grant support, which stimulated development of the instructional applications, has been absent for administrative applications. However, the success of the two pioneers has already begun to spread among the others.

With the three larger universities there is a greater reluctance to shift their administrative data processing to TUCC, although Duke has already accomplished this for their student record processing. One problem which must be overcome to complete this evolution and allow these universities to spend administrative computing funds on the more economic TUCC machine is the administrators' (understandable) reluctance to give up a machine on which he can exercise direct priority pressure. The present approach to this problem is to extend the allocation and scheduling algorithm to guarantee a portion of the central machine to each founding university's administrative data processing needs. Another problem is the development of confidence in the available back-up resources. It would probably require additional computing resources at TUCC if this option is elected by any of the universities.

Hardware Homogeneity

While not a real problem at present, it would appear that TUCC has locked itself into IBM compatible systems. This has simplified the

development of the network by permitting compatibility problems to be ignored, but it may restrict the alternatives for future growth.

8. Lessons Learned

1. User Services

A very important lesson that was learned is that personal communication must exist and be kept alive at all levels.

"It is amazing how misinformation can spread if there does not exist a vigilant system for keeping people informed... Experience has shown us that if we relax ..., then little things that may go wrong may sometimes be magnified completely out of proportion to their importance and begin to become a source of irritation at some point in the system. The central facility must therefore have a high coefficient of sensitivity to the needs of all users."(Davis, p. 4-1-2)

The earliest recognition of this fact was the hiring, at the time of the formation of TUCC, of a Manager of Information Services at TUCC. His responsibility is the documenting of all operating systems, services and policies. An elaborate system of memoranda series with distributions to various relevant groups was developed. This lesson also explains the "circuit riders" who were employed by NCCOP (now NCECS) to regularly assist its client colleges.

2. Wholesaler-Retailer Concept

TUCC's implementation of the wholesaler-retailer concept (as explained in section IV-above) was designed as a mechanism for the administrative protection of the interests of the three founding universities and the NCECS schools.

Because each of the universities and NCECS is guaranteed a minimum percentage of utilization of the central machine (in effect, a virtual machine for each), they have the assurance that they can take care of their users' needs as would be the case with totally independent

facilities. The scheduling algorithm also allows each to define and administer quite flexible, independent priority schemes.

Since the local centers and NCECS are the retailers of all computer services, whether produced locally or purchased on a wholesale basis from TUCC, they are not in competition with TUCC. Users are also able to turn to local personnel for all required services, and receive a single bill.

There are several structural devices which serve to protect the interests of both the wholesaler and the retailers. At the policy making level this protection is afforded by the Board of Directors, which is appointed by the Chancellors of the three founding universities. Typically each university allocates its representatives to include its business interests, its computer science instructional interests, and its other computer user interests. The University Computer Center Directors sit with the board whether or not they are members, as do the Director of NCECS and the President of TUCC. An example of the policy level function of the Board is their determination, based on TUCC management recommendations, of computing service rates for NCECS and other TUCC users. (Williams, 1972)

At the operational level there are two important groups, both normally meeting each month. The Campus Computation Center Directors' meeting includes the indicated people plus the Director of NCECS and the President, the Systems Manager, and the Assistant to the Director of TUCC. The System Programmers' meeting includes representatives of the three universities, NCECS and TUCC. In addition, each of the universities has the usual campus computing committees.

3. Neutrality of Site

The neutral location of the central computer is felt to be "one of the chief factors contributing to the political stability of TUCC." (Brooks, et. al.) An earlier unsuccessful experience with a computer jointly

owned by NCSU and UNC-CH, but located at Chapel Hill, had shown that "the psychological and political consequences of location could not be tele-processed away." It is recognized that a neutral location requires extra cost, but this is felt to be "an indispensable expense."

Annexes

A. Bibliography

Brooks, Frederick. P., Jr., Ferrell, James K. and Thomas M. Gallie. "Organizational, financial and political aspects of a three-university computing center." <Proceedings IFIP Congress 1968>, pp. 923-927.

Davis, M. S. "Economics -- point of view of designer and operator." <Interdisciplinary Conference on Multiple Access Computer Networks> (Austin, Texas, April 20-22, 1970), University of Austin and The Mitre Corporation, pp. 4.1.1-4.1.7.

Freeman, David N. and Robert R. Pearson. "Efficiency versus responsiveness in a multiple-services computer facility." <ACM National Conf.>, 1968, pp. 25-34.

Freeman, David N. and Joe R. Ragland. "The response-efficiency tradeoff in a multiple-university system." <Datamation>, Vol. 16, No. 3, (March 1970), pp. 112-113.

Grobstein, David L. and Ronald P. Uhlig. "A wholesale retail concept for computer network management." 1972 FJCC, pp. 889-898.

International Business Machines, Inc. "In North Carolina, computing power for education." <Computing Report>, 9:2 (Summer 1973), pp. 2-6.

Parker, L. T., Gallie, T. M., Brooks, F. P. and J. K. Ferrell. "Introducing computing to smaller colleges and universities -- a progress report." <CACM>, 12:6 (June 1969), pp. 319-323.

Williams, Leland H. "A functioning computer network for higher education in North Carolina." 1972 FJCC, pp. 899-904.

B. Special Vocabulary

NCCOP - North Carolina Computer Orientation Project

NCECS - North Carolina Educational Computing
Service

TUCC - Triangle Universities Computation Center

Oregon State Regional Network

I. Introduction

The Oregon State Regional Network is representative of the large number of centralized "star" networks serving a regional clientele. It was organized to provide educational computing services to a number of geographically dispersed institutions, and is not concerned with research into the technology of networking.

II. Network Identification and General Description

A. Sponsoring Organization

The network was sponsored by Oregon State University with support from the National Science Foundation.

B. Purpose/mission of Network

The regional network was established in connection with a two-year project with National Science Foundation support to develop and appraise instructional uses of computational facilities provided through computer terminals on-line to a central computer facility. The objectives of the project were:

1. To provide faculty and students at the participating colleges with computing resources available through terminals which have direct access to a central computing facility.
2. To develop special instructional programs and materials suitable for regular as well as "short" courses in the use of computers in an educational environment.
3. To appraise the usefulness in instructional programs of the facilities offered with reference to the instructional needs of each institution.

C. Status and Topology

The system now supports a network of more than 200 remote terminals with approximately 75 terminals active concurrently. Approximately 35 terminals

are located at other universities and colleges of the network. The network serves instructional, administrative and research applications, and may be reaching saturation. Acquisition of new computing hardware is being contemplated at the present time.

D. Technology Summary

The Oregon State University Regional Computer Network consists of a central computing facility at the Oregon State University campus in Corvallis, Oregon, which serves some sixteen institutions of higher learning in Oregon. The central facility runs in a time-sharing mode under a special operating system developed at Oregon State University. Remote users are connected to the central facility by low speed teletypewriter lines.

The principal resource at the computation center is a CDC 3300 with a memory capacity of 98K 24-bit words. Peripheral devices include a card reader and punch, line printer, four magnetic tape units, five magnetic disc units, a 200 million character mass storage disc unit, 16 CRTs, a plotter and a PDP-8 minicomputer which serves as a communications front end. The PDP-8 also serves as a telephone line interface for 180 remote terminals. During 1972 remote batch capability was added using card readers and line printers.

The operating system, OS-3 (Oregon State Open Shop Operating System) was designed and implemented by the Oregon State Computer Center. It permits time sharing operation in a variety of languages, including ALGOL, FORTRAN, BASIC, OSCAR (a conversational language for all types of users), EDIT (a file editing language), and others.

E. Future Plans

The regional network described here was an experiment of fixed duration and limited to academic computing. The State Department of Higher Education is currently considering a proposal to establish a computing consortium among all nine of the institutions of higher learning in the state and to establish and develop a computer network to serve both academic and administrative needs. It would be structured similar to the regional

network, with a central facility and staff at OSU and remote stations at the other participating sites.

III. Network Organization

A. Structure and Extent

The organization of the network is embedded in the organization of the regional computer center. Special organizational elements, exclusively concerned with network operations are a regional coordinator who reports to the regional computing center director, a regional steering committee, and campus coordinators resident on the individual campuses. Close liaison is maintained with the Teaching Research Division, an arm of the Chancellor's Office, which represents all institutions of the Oregon State System of Higher Education.

Computer Center Director

The regional computing facility is under the direct supervision of a central administrative officer, the computer center director. He has the authority to enforce adherence to established procedures, observation of priorities, and conformance to established schedules. The director is assisted by a steering committee.

Steering Committee

The regional steering committee considers policy matters affecting regional projects, terminal end users, and recommends action to the regional coordinator and the computer center director. The committee helps to maintain uniformity and workability of operation and services, where this is in the interest of participating institutions. It acts as a developer of procedures for network users. It is responsive to all network participants and considers the effects of all actions on local centers. Members are elected to the steering committee by the participating schools.

Campus Coordinators

The campus coordinator acts as the manager of instructional computing on his individual campus. He needs to have a knowledge of available computing facilities and of specific campus computing needs. He works closely with all users and coordinates interdisciplinary requests and problems. This assignment is considered to require at least half time availability of the designated faculty member. Specific functions of the campus coordinator are:

Coordinate use of remote terminals with local facilities;

Act as campus-wide focal point for utilization, dissemination and facilitation of instructional and research uses of the regional computing facilities on his campus;

Serve as a member of the local institution computer committee;

Facilitate training for faculty;

Coordinate remote regional facility maintenance, regional staff visits and workshops;

Attend regional conferences;

Report development of computer-related curriculum material and other documentation to regional project coordinator;

Prepare and coordinate interim and annual reports regarding institutional participation in the network;

Report news items to regional newsletter editor;

Be aware of all projects involving curriculum development teachers, curriculum writers, consultants and learning and evaluation specialists;

Participate in local budget recommendations

Involving utilization of regional facilities on his campus.

The final project report recommended that the campus coordinator report to either the dean of instruction or the dean of administration. It was also suggested that on some campuses it would be beneficial for the Campus Coordinator to have an advisory committee to assist him in making decisions relating to the allocation of resources.

B. Functions Performed

1. Planning

The emphasis during the initial portion of the project was on three items: 1) developing useful and reliable services; 2) assisting individuals and classes to become fully cognizant of the services and how they could be used; and 3) a preliminary exploration of the curricular changes brought about by the introduction of the facilities. The emphasis throughout the last year of the project was on the development and evaluation of techniques and materials relating to the role of computers in the academic environment.

2. Installation

The time-sharing computer facility of the OSU Computer Center has been the basic computational resource of the network. Access to the center is through remote terminals located at each of the participating colleges. Under the grant they were provided with terminals, communications costs, computer time, and consulting services. The installation requirements for this type of arrangement are minimal.

3. Operations

Because of the star configuration of the network, operational concerns specific to the network are minimal. The center is operated as any other large multiprogrammed center serving interactive users.

4. User Services

User services have primarily been provided by three means: publications, seminars and personal interaction.

Publications include manuals for all services available as well as a computer center newsletter published on a regular and timely basis. These are necessary but not sufficient to the success of the project.

In an effort to promote the use of the network, a series of conferences were held at various campuses to introduce the faculty to some of the instructional uses that can be made with the computer in the classroom. Each conference lasted two days and concentrated on a specific academic area. The participating faculty were presented with ten to fifteen examples of actual classroom uses of the computer followed by an opportunity to use the material and to modify and adapt some of the examples into their instruction. Whenever possible, each example was presented by an instructor who had used the material in his class, and Regional Computer Center staff were on hand to help the faculty with any problems they had in using the terminal, the system or the materials. The faculty attending the conferences became very enthusiastic about the possibilities of the computer in the classroom. However, it was found that without some type of follow-up the enthusiasm wanes.

The follow-up is provided through personal interaction. A Regional Computer Center staff member, familiar with the academic area and the instructional materials, visited the participating schools during the immediate weeks following the conference. He discussed with the faculty who attended the conference and other interested faculty possible applications in their classrooms. The role of the local campus coordinator in providing personal assistance has already been discussed. Within the course of one term, following this procedure, the faculty who have attended the conferences introduced the

computer into their classrooms on a regular basis.

C. Interfaces (relationships with other organizations)

The regional computing center has worked closely in the past with the Teaching Research Division, an arm of the Chancellor's office which represents all institutions of higher learning in the Oregon State System. This division is concerned with improvements in the teaching procedures at various levels of instruction. The division has assisted in two areas: 1) direct assistance to faculty in courses using computers, and 2) evaluation of user reaction, utilization patterns, and impact of the computer on instruction.

The other external relationship of interest is with the other universities involved in the CONDUIT project. Oregon State University, Dartmouth College, the North Carolina Educational Computing Service, and the Universities of Iowa and Texas have been funded by the National Science Foundation in a cooperative project in educational computer usage and program exchange. Each of these schools have developed active computer networks and a significant base of curriculum materials. The CONDUIT project involves the formation of a central organization and staffs at each of five schools to design the procedures necessary to transport about 75 curriculum units and to implement these procedures in the five networks. CONDUIT will quantify this exchange process including all costs, faculty training requirements and user feedback.

IV. Financial and Legal Concerns

A. Capitalization

The National Science Foundation, through its Office of Computing Activities has funded 20 regional computing activities during the period 1968-1969. One of the first three such grants made was to Oregon State University in 1968 in cooperation with six other colleges in Oregon. The principal investigator under the grant was Dr. Larry C. Hunter of OSU. This grant has since expired, and current network activities are self-supporting. Campus computer center operations are supported by

the local university budget. The regional center is supported by state funds and usage charges.

B. Accounting

Because of the "star" configuration of the network, accounting was not a problem. All users maintained accounts in the central machine at OSU and were billed (or charged against their portion of the grant) from there.

C. Regulation

The network was regulated in part by the National Science Foundation by the terms of its grant and in part by the Chancellor's Office of the State of Oregon. Only institutions of higher learning in Oregon could participate.

Since all participants of the network were located within the state of Oregon, intrastate tariffs applied for all telephone lines used. The network was configured as a "star" or single central timesharing system with remote users, so there were no other issues related to tariffs.

D. Security

The only security controls in the system are provided by the log-on sequence of the central time-sharing system.

V. Conclusions

A. Summary of Problems

Due to the use of a well-known and straightforward network design (the star configuration) and the emphasis on providing service rather than performing research on networking, there were no notable technical problems. The primary problem was in promoting the use of the facility by those to whom it was offered.

B. Lessons Learned

The project's final report suggested that the success of a regional computing activity required quick and effective methods of communication

between the remote site and the central staff. The following general principles were offered:

1. There must be a willingness of regional participants to work out mutual problems, to cooperate, to compromise if necessary, and to consider the progress of all users.
2. A regional center should be considered a service organization to provide services which cannot be provided efficiently otherwise.
3. The activities of the regional group are under a steering committee which considers policy matters affecting regional projects, terminal use and users, and recommends action to the Regional Coordinator and the Computer Center Director.
4. The Regional Steering Committee can help to maintain uniformity and workability of operation and services.
6. The regional facilities and activities should augment each school's local facilities and services. The use of the terminals and facilities on each campus should be under the jurisdiction of that school and operated for that respective school.
7. Location of regional facilities is of little concern. More important is ease of access, reliability and personal service.

Annexes

A. Bibliography

Hunter, Larry C. "A final report on OSU regional computer center project." Submitted to the National Science Foundation, March 22, 1971.

Office of Administration, Oregon State Board of Higher Education. "Computer services in the Department of Higher Education." January 1, 1973.

Weeg, Gerard P. "The role of regional computer networks." <Computers in Instruction: Their Future

for Higher Education>; Rand Corporation: Santa Monica, CA, July 1971; pp. 55-66.

B. Special Vocabulary

OS-3 - Oregon State Open Shop Operating System

OSCAR - Oregon State Conversational Aid to Research

TYMNET

I. Introduction

TYMNET is a distributed national network of heterogeneous computers operated for profit by a major time-sharing company. The continued operations of this network serves to demonstrate that such facilities are commercially viable.

II. Network Identification and General Description

A. Sponsoring Organization

Tymshare, Inc., with headquarters in Cupertino, California, was formed in 1966 as a commercial time sharing company. It has grown to a company with annual sales of some \$21 million and about 450 employees, making it the largest independent in the time sharing field. The total number of individual users of Tymshare services is in excess of 10,000, and they represent over 150 separate organizations.

B. Purpose/mission of Network

TYMNET exists primarily to make available the commercial timesharing services of Tymshare, Inc., although the capabilities of the communications network itself have been marketed separately to customers wishing to connect their own terminals to their own computers. The network is designed for interactive terminal to computer communications, although computer to computer connections are possible.

C. Status and Topology

The network has been operational since 1969 as a commercial service. It is presently serving over ten thousand interactive users (800 simultaneously) in over 70 cities throughout the United States and Europe (Paris, France).

The network serves to interconnect approximately 40 host computer systems and contains some 100 communications nodes in a multi-ring configuration. Figure 1 illustrates an abbreviated topological map of the network.

TYMSHARE, INC.
TYMNET

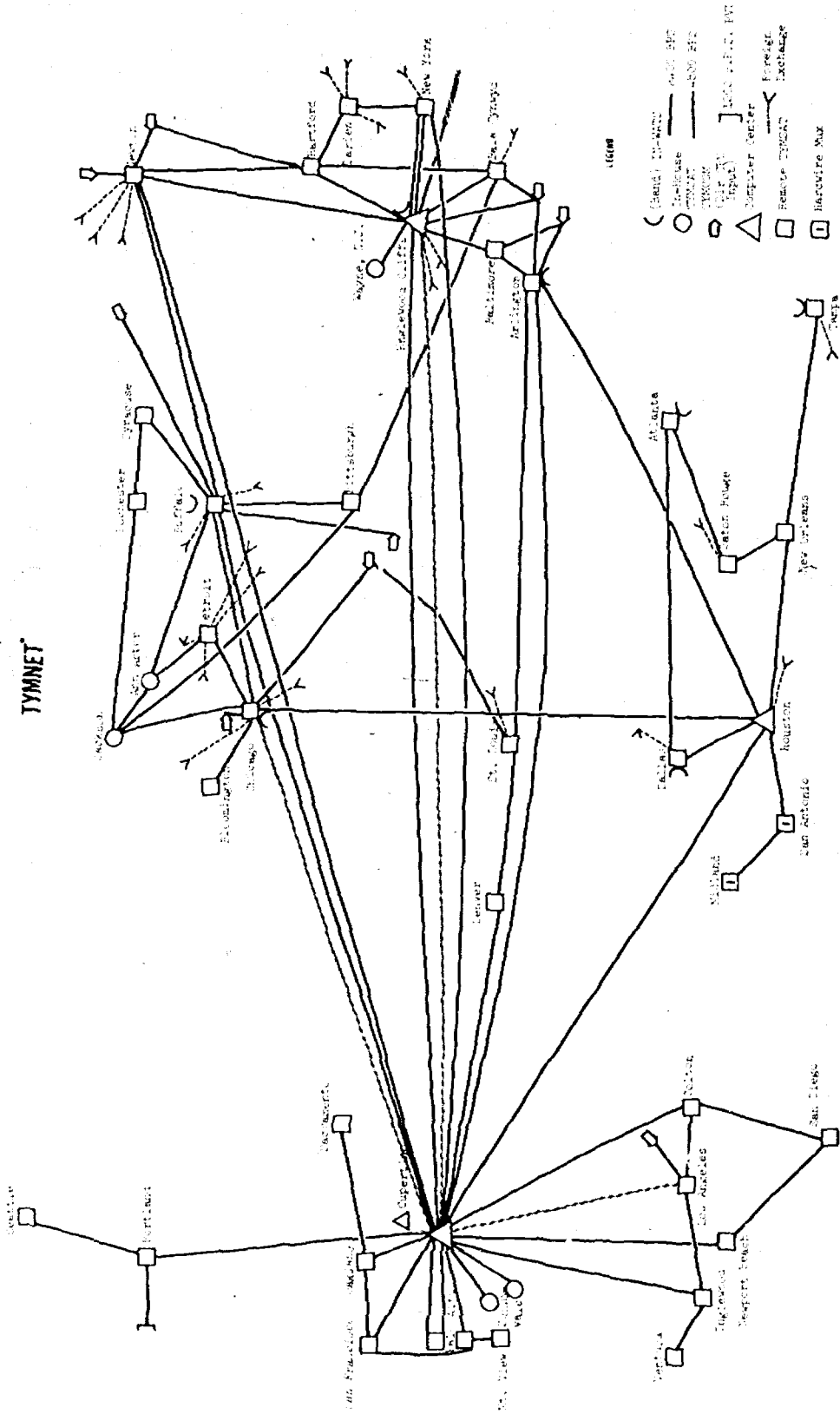

D. Technology Summary

The network consists of approximately 100 minicomputers (Varian 620/1, 620/L and 620/L-100) called TYMSATs interconnected by common carrier voice grade facilities. The TYMSATs serve in two different capacities, to connect host systems and terminals to the network.

The "base" TYMSAT is responsible for acting as both a message switching computer in the communications network and as an interface to the network for host or service computers. When the service computer is one of those generally supported by Tymshare (such as an XDS 940, IBM 370/158 7 or DEC PDP-10), the TYMSAT has been programmed as a communications controller replacing the standard components for that function. Computers of a type not employed by Tymshare have thus far been interfaced to the net through their standard communications controller (e.g., IBM 270X or 3705 for an IBM 360 or 370) so that the TYMSAT appears as a complex of terminals to the controller.

The base TYMSATs are each connected to a service computer in a one-to-one or one-to-two fashion (approximately forty throughout the country) and to one another either directly or through an intermediate base TYMSAT in a multiple ring or distributed manner. The circuits used are either 2400 or 4800 bps synchronous, full-duplex, private leased lines.

The "remote" TYMSATs act as store-and-forward computers and as concentrators for user terminals. In addition, some remote TYMSATs with added hardware and software can support local printers in the 600 to 1200 baud range. Each is capable of supporting up to thirty-one asynchronous, full-duplex modems allowing for terminal speeds in the 110 to 300 bps range. The remote TYMSAT can identify a terminal (baud rate and carriage return delay time) by the first character typed. It is possible to allow a terminal to connect with two different baud rates for input and output. In addition, ASCII conversion is provided for non-standard terminals and echoing if the user terminal is operating in echo-plex mode. ...

The remote TYMSATs are connected to the base TYMSATs and thus the service computers through a ring configuration whereby a circuit passes through a number of remote TYMSATs and one base TYMSAT. Store-and-forward techniques are used to exchange information between any remote TYMSAT and any base TYMSAT. The circuits connecting the remote TYMSATs are again 2400 and 4800 bps synchronous, full-duplex, private leased lines.

Blocks are transmitted through the network over full-duplex virtual circuits. These circuits are established at log-in time and exist for the duration of the connection. These circuits are established by software in the TYMSATs which associate an input channel with the appropriate output channel at each switching point. A circuit is established by the "supervisor in active mode" (Sam). When a user connects to TYMNET, he is originally communicating with the Sam, which, after the appropriate exchange of information, will establish a circuit from that user's terminal to the desired service computer by selecting the proper TYMSATs to complete the virtual circuit.

The "supervisor in active mode" is so named because it is a function which can be taken over by backup supervisors in the event of failure. A backup supervisor will become active by detecting a failure, polling the TYMSATs to get network status information, and assuming the active role. This sequence does not disturb users on processors other than the one whose supervisor failed.

It should be noted that in the event of a processor failure, its base TYMSAT can still function in the role of a network store-and-forward computer. Since virtual circuits are established and fixed for the duration of processor connections, recovery from a physical line failure is not as clean. When a line fails, users communicating through virtual circuits using that line in their definition must reconnect.

E. Future Plans

Tymshare, Inc. continues to expand its network coverage as business conditions justify. The

company is also starting to use higher-speed lines and alternate suppliers.

III. Network Organization

A. Structure and Extent

Tymshare, Inc. is organized similarly to most corporations which produce and market goods nationally. They have a home office with a central staff for planning and control in Cupertino, California, and regional and branch offices throughout the country and in Europe.

B. Functions Performed

1. Planning

The network is privately managed in its entirety, and all planning for its growth is done by the Tymshare, Inc. corporate staff. The network topology, however, has not been laid out following any specific design strategy, but has just grown in response to customer needs and the business expected in certain areas.

2. Installation

All matters relating to installation (such as leasing phone lines and the delivery and attachment of TYMSATs) are handled by Tymshare, Inc. as part of the usage contract with the customer.

As usage grows and bottlenecks occur, two main courses of action are taken by Tymshare. As an interim step, the "preferred routing" definitions for some terminals can be changed, so as to reroute data and thus relieve the bottleneck. Also, additional leased lines can be ordered; it normally takes about six weeks to obtain such lines. The ring structure of the network provides considerable flexibility in the management of the physical network.

3. Operations

The network is controlled by a Network Supervisory System. This is a control program

that is resident in four host computers. Currently, two of these host computers are at Cupertino, California, one is at Englewood Cliffs, New Jersey, and one is at Paris, France. However, only one of the programs is in control of the network. The other three have a "pecking order" for taking over control of the network in case the active supervisor shows any sign of not being able to handle the job. If the network should become segmented, such as transmission across the Atlantic be disrupted, then each segment can be run independently until communications have been reestablished.

The network has proved to be very reliable, with an average of only 1.4 failures per year for the TYMSATs. Preventive maintenance is performed twice per year on the TYMSATs.

4. User Services

Tymshare, Inc. has an extensive organization of marketing representatives throughout the country who also continue to provide service to customers after they contract to use the network. The company offers many proprietary software packages for use on the network, and is continuing to develop more.

As a profit-making company, it is reasonable to assume that Tymshare will be quite responsive to user needs. For example, remote batch service is not presently offered, but will probably be added when user demands dictate.

C. Interfaces (relationships with other organizations)

Since Tymshare is a company which markets products to organizations rather than to individual consumers, each customer represents an interface with another organization. As outlined below, many organizations, both private and public, use TYMNET in a "shared" (really "value-added") mode of operation as provided for in FCC Tariff No. 260. Tymshare obtains circuits from the common carriers and "shares" the use of them with the additional network functions sold to its customers.

Besides Tymshare itself, the National Library of

Medicine in Bethesda, Maryland, is the largest user. With nation-wide access to their Medline Data Base on an IBM 370/155, NLM serves more than 200 libraries, hospitals and university medical centers. NLM has been using the network since February 1972.

IV. Financial and Legal Concerns

A. Capitalization

Tymshare, Inc. is a for-profit corporation capitalized by the sale of stock to private investors.

As listed in the 1972 Annual Report, Tymshare's investments in computer systems and terminal/communication equipment were \$5.05 million and \$4.49 million, respectively.

B. Accounting

Tymnet can and is being used in several ways. The principal use is for providing customers with time sharing services, both computing services and application packages. The network allows a customer to use a specific resource, such as a particular data file, that may be located at a Tymshare computing center on the other side of the country. In addition, the network allows Tymshare to make "rolling use" of its resources by diverting peak loads occurring at particular hours of the day to computers located in other time zones.

Another use of the network is where the customer has both a computer and terminals connected to the network, and the Tymshare computers do some of the processing. Data files may be exchanged between a user's computer and Tymshare computers as required.

Still another way to use the network is by a joint use arrangement, which is allowed under Federal Communications Commission (FCC) Tariff 260. In this type of usage, the customer contracts for a specified percentage of the Tymnet capacity -- say 1% averaged over a one month period -- for communicating between the customer's terminals and the customer's computer. In this instance, the Tymshare host computers are involved to set up the

call routing and to guarantee their stability, but not to process data. An agreement is signed with the Telephone Company whereby it bills the company for the specified percentage of the communications charges. In addition, Tymshare bills the customer for its "value added" services.

TYMNET's standard price list is as follows:

Description -----	Monthly Charges -----
Each log-on to host computer	\$.50
Accumulative time connected to host for all terminals:	
0 to 500 hours	3.00/hour
next 1500 hours	2.50/hour
next 3000 hours	2.00/hour
next 5000 hours	1.50/hour
each hour over 10,000	1.00/hour
Transmission of characters between user and host computer	.125/1000 characters
TYCOM-III rental (30 ports)	2150.00/month
AT&T Joint Use Charge (billed by AT&T)	7.50/leased lines used/month
One time installation charge	1000.00

C. Regulation

Aside from tariffs (discussed above) and the normal laws affecting all private businesses, TYMNET is not regulated.

D. Security

When a user accesses the system, a Tymsat accepts his terminal identification and prompts with the message PLEASE LOG IN. He is immediately connected to the network supervisor which checks the Master User Directory and validates the user name and password. The supervisor then determines which computer is associated with that user and connects him to the appropriate system. At that time, the supervisor transfers control to that system and data is transmitted directly, rather than through a central point as in a star-type network. Whenever

he logs out, he is returned to the network supervisor which again asks for the log in sequence.

Users may be validated on multiple systems, in which case they must identify the system to which they wish to be connected at login-time. A single user's password is the same on all systems.

The supervisor, in maintaining records, provides a complete chronological log of all events in the network. The supervisor also permits manual intervention and survey, including the ability to determine how many users are connected to a host and to determine where host users have originated a call and which nodes they pass through en route.

V. Conclusions

A. Summary of Problems

TYMNET continues to have a number of technical problems which affect the level of service which can be offered. No facilities for remote job entry are presently provided, although this service is under investigation, and synchronous terminals cannot be supported. The capabilities of the Varian 620's place a limit on the ability of the network to handle much faster communications lines than are presently in use. The present strategy of disassembly and reassembly of all messages at every node also limits the capacity for handling increased traffic. Terminal interfaces to the TYMSATs are also bit-oriented, thus limiting the number of terminals which a single TYMSAT can accommodate. Tymshare recognizes this "bit banging" to be inefficient, and is investigating the use of more sophisticated terminal interfaces and message forwarding strategies.

B. Lessons Learned

Tymshare has demonstrated that value-added networks can offer an economically viable product.

Of equal importance, Tymshare's experience demonstrates that a distributed network can be adequately managed.